

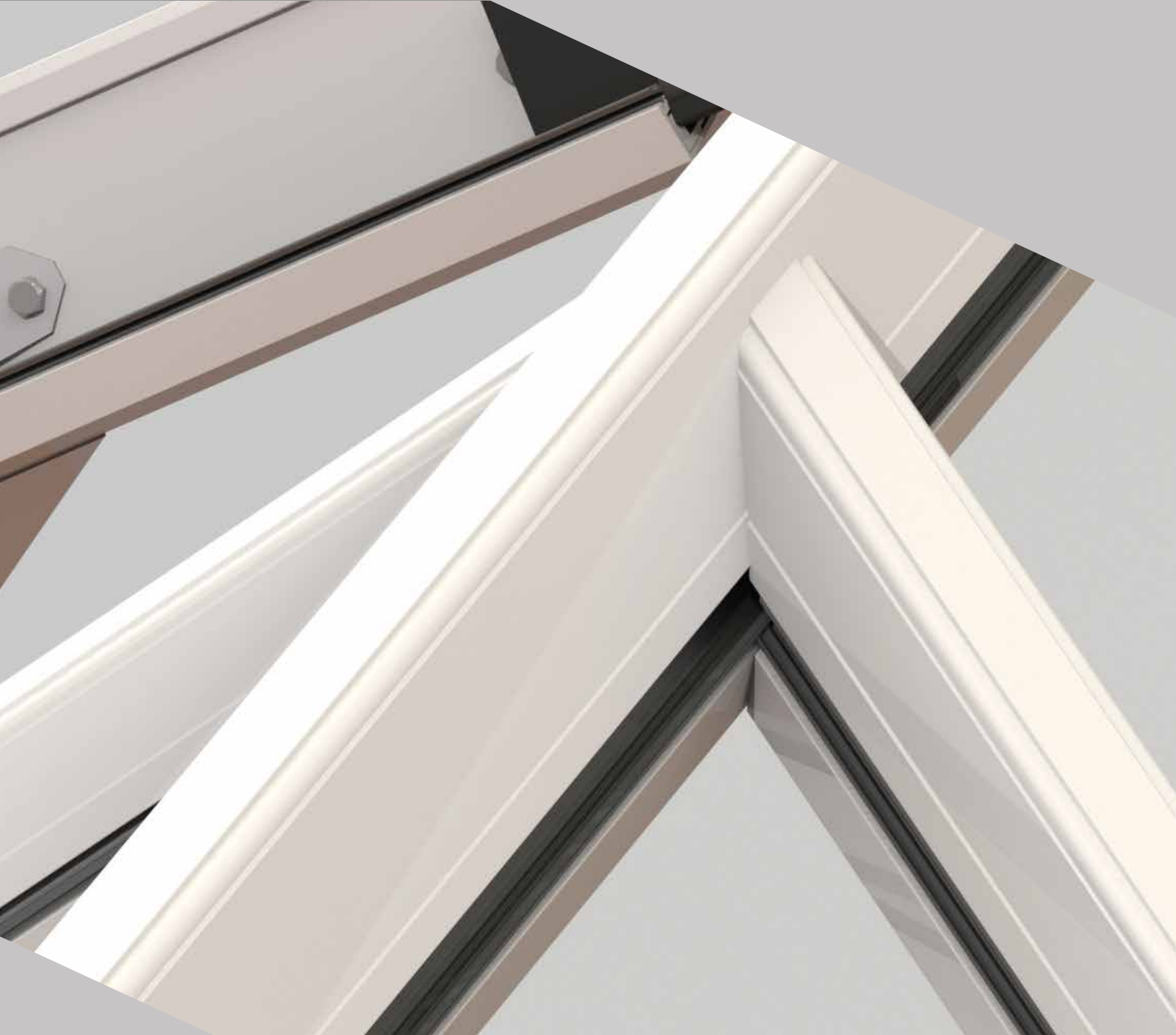

WENDLAND

R O O F S O L U T I O N S



Installation Guide

Wendland Mk5 Roof System

Thank you for choosing the Wendland roof system.

This guide is designed to make fitting as straightforward as possible.

Before you commence installation of the roof, please;

- 1) Take a moment to read these two introductory pages before reading the rest of this guide.
- 2) Do not fix the frames down at this stage – only temporarily ‘pin’ the frames to the house wall (one fixing each side) to allow the conservatory to ‘float’.

Wendland have been making conservatories since 1995. We have continued to invest to improve the features that the homeowner will appreciate and that should make your life easier. Any feedback - positive or negative - is welcomed so we can make our systems even better.

Please contact the Tech Support Team on 01200 452 318 or email customerservice@wendland.uk.com

CONTENTS

section 1	Pre-installation checks	4
section 2	Roof vent sash	5
section 3	Edwardian roof installation	6-12
section 4	Tie bars	12-13
section 5	Roof vent installation	14
section 6	Box gutter installation	15
	Box gutter jointing	16
	Box gutter support	16-17
	Box gutter raised back	17
section 7	Valleys	18-19
section 8	Lean-to installation	19
section 9	Gable installation	20- 21
section 10	Hip lean-to installation	21
section 11	Muntin bar installation & Capping removal	22
section 12	Gutter Cover installation	23- 27
section 13	Internal Pelmet installation	28- 55

ALL box gutters (especially those with tie bars or joints) MUST be supported.

We recommend several types of support for box gutters including brick piers. See pages 22-23 for details of our solutions. Fitting a conservatory box gutter without adequate support will lead to structural failure. Please take the correct steps BEFORE installation.

TOOLS REQUIRED



10 & 13mm
Socket Spanner



Deadblow
Hammer or White
Rubber Mallet



No. 2 Pozidrive Bit



5mm Wide Flat
Blade Screwdriver



Hack Saw



Drill/Screwdriver



Long nose pliers



Gasket Shears/
Snips



4.5mm Drill Bit



Sealant Gun



2 x 5mm Allen
Keys (Vic fixing kit)



17mm Open
Ended Spanner -
Tie Bars



Spirit Level



Tape Measure



Anglefinder



Plumb bob

Eaves to frame fixings, host wall fixings and ridge top cap flashing trim screw not supplied.

General points

Care should be taken when handling components that are seen by the homeowner, as surfaces may be scratched if not handled with care. Choose a suitable area for unpacking the components and always check them before fitting. Any claims for missing or damaged parts are only accepted in line with our standard terms and conditions of sale.

Health & safety

Site safety is paramount. The Construction (Design & Management) Regulations 2015 apply to the whole construction process, on all construction projects from concept through to completion. Compliance is required to ensure construction projects are carried out in a way that secures health and safety. The installation company shall be responsible for the safety of all of the fitting team, the customer and members of the public.

The Surveyor should have carried out a risk assessment to reduce risk on site and this should have been discussed with you prior to starting.

Please use safe working platforms and ladders that comply with BS EN 131. Always use equipment in line with manufacturers recommendations. Personal Protective Equipment – such as goggles, mask and ear defenders – should be used when, for example, grinding out for the flashing.

Careful consideration should be given to the safe disposal of all packaging – our packaging is predominantly made from recycled materials and can be readily recycled.

Product

The roof kit is supplied with a location plan, part check list and this installation guide. The location plan is used to match individual components to their respective position on the roof. Our numbering convention always starts at the top left, against the house wall as you look from outside the conservatory back at the host wall.

The majority of aluminium and PVCu components contain identification codes, usually by inkjetting or labelling – should you need to re-order a part this should help. Please ask for a copy of our product guide to keep in the van, which will give you further assistance with future identification.

Sealing

It is important to use the correct sealant when sealing the roof.

1. For roofs glazed with Polycarbonate (or standard sealed units) a low modulus neutral cure brand of silicone must be used
2. For roofs glazed with Conservaglass or other true 'self cleaning' glass, then MS Polymer sealant such as Rotabond 2000 must be used.

Sealed Units

All protective handling tape must be removed prior to installation. For the correct selection of sealant please see above

The Superstructure

Check the Dwarf wall or Plinth for being level all round. Ensure that all frames which abut the host wall are vertically plumb, which will then allow perfect alignment with our eavesbeam. Before starting to install the roof, please check the condition of the host wall and whether it's plumb – depending upon what you find, these conditions can seriously affect the final integrity of the roof.

PRE INSTALLATION CHECKS



Unpack the roof vent sash and assemble, see section 2. If possible, do this in the factory the day before.

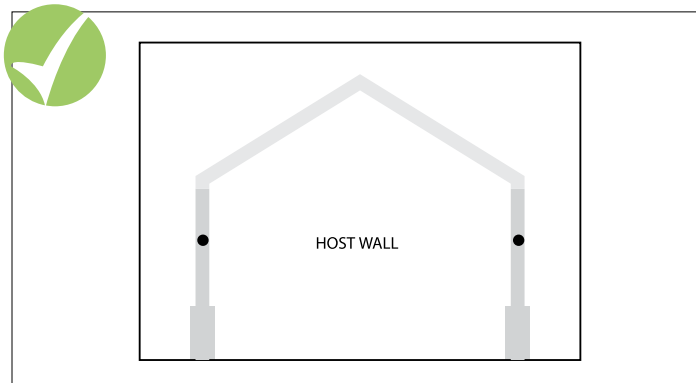

At this stage do not fix the frames down - pin only to the house wall (one fix per side) to allow the conservatory to 'float'.



Take the glazing bars from the roof pack and check the anchor clips are fitted (the clips are always at the top of the slope). On the eaves beam check that there are the correct amount of twin and single bolts and that the glazing support trim is fitted.



Attach the glazing bar end cap fixing blocks - as access restrictions (box gutter situations) may prevent easy attachment later.

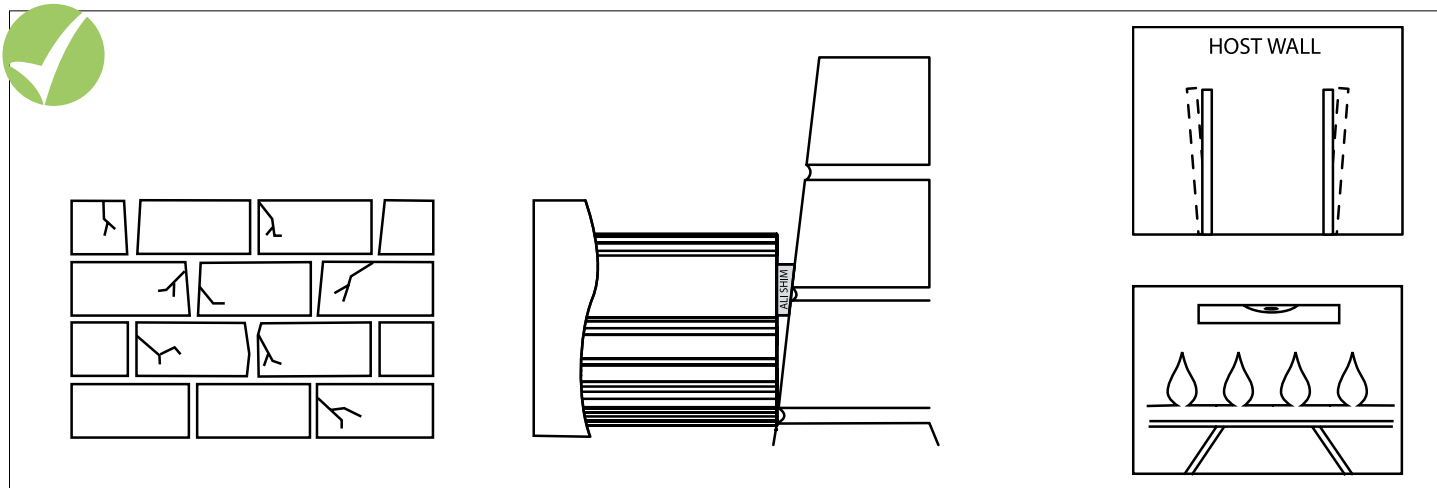

Check the condition of the host wall as this may affect the quality of the final installation. Check the host wall is plumb - any running in/or out should have been accounted for by the surveyor. If not, the ridge and starter bars may require packing out with aluminium shims. Correct alignment in this area is critical to a successful installation - Plumb frames/level ridge.

Only use the specified fixings - never be tempted to substitute alternative sizes/gauges.



Use the correct sealant

ROOF VENT SASH

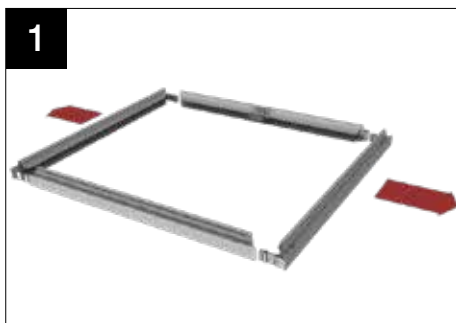

Unwrap the sash and pull two side sections out as shown above.

Remove any protective handling tape around the perimeter of the unit prior to installation.

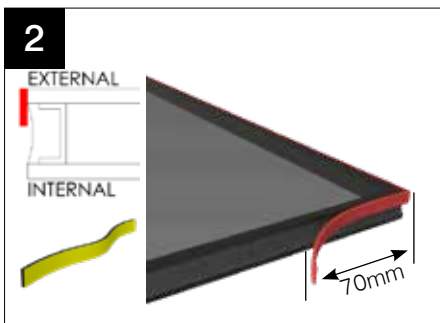

Apply length of foam tape directly to the lower edge of the outer pane of the glass unit as shown. Start by applying the tape 70mm up the side of the glass unit and continuing to wrap around the lower edge of the glass unit, finishing 70mm up the opposite side.



For pitches below 10° it is recommended that the glass is sealed in by running a bead of silicone along the length of each sash section as shown above. For pitches above 10° it is advisable to do the same.

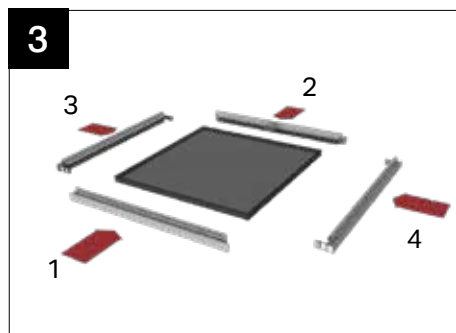

Once tape has been applied, assemble the sash in the sequence shown above and ensure the tape is directed against section 2.



If the pre-drilled holes appear out of alignment as shown above in red simply slacken off the factory fitted screws.



The two sections can then be readjusted so they are in line and square. Then the non factory fitted screws can be fixed down.



Finally re-fasten the factory fitted screws.



On the hinge side of the sash fill the hole shown above at either end with a blob of silicone.

NOTE The roof vent has been successfully tested by the BBA at 25° up to 1200Pa without sealant.

EDWARDIAN INSTALLATION

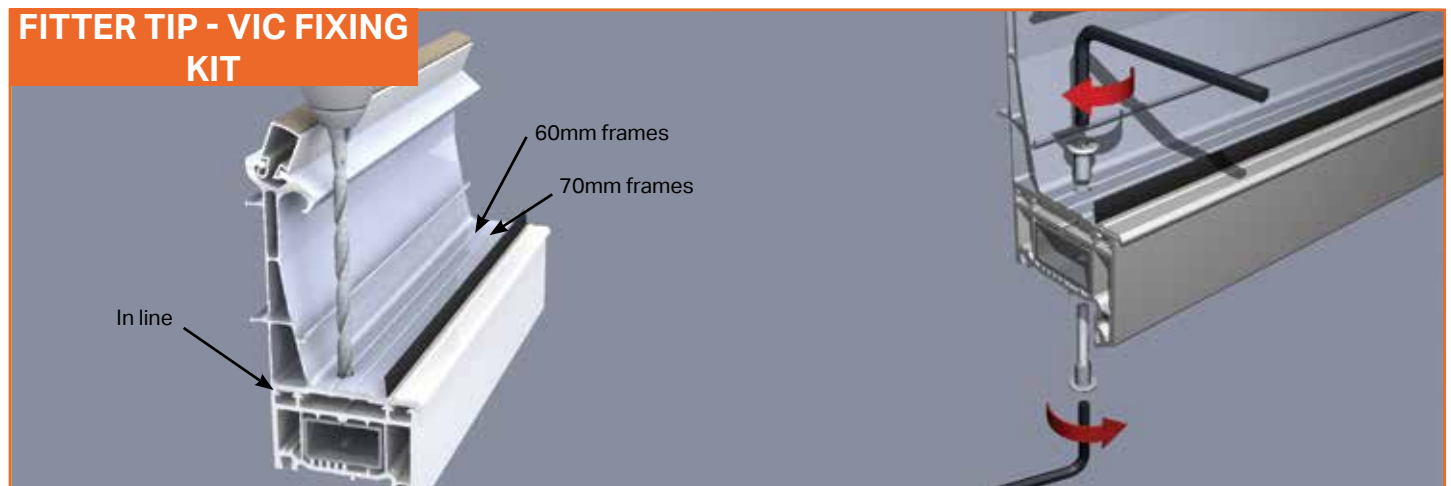

When using the Victorian Fixing Kit drill a 10mm hole through the base of the eaves beam and completely through the head of the window frame. Ensure that both sides of the 10mm hole are accessible for Allen key fixing. Use a 5mm Allen Key to tighten the fixings. The eaves beam should be fixed at 450mm centres and within 200mm of each corner. **THIS IS THE RECOMMENDED FIXING METHOD**

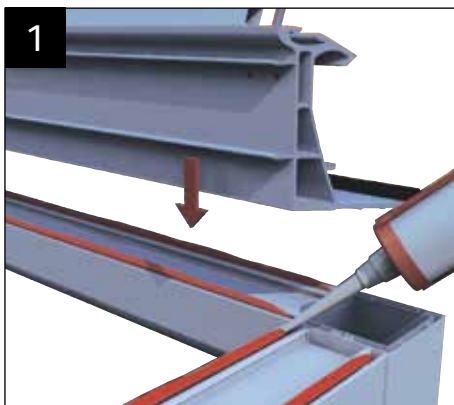

1 Apply a continuous bead of silicone to the front and rear inner legs of the window frames. Fit the initial piece of eaves beam ensuring that the inside face of the eaves beam is flush with the inside face of the window frame.

Please note: Ensure that the under gutter trim is fitted to the eaves beam and all bolts are in situ prior to fixing to the frames.

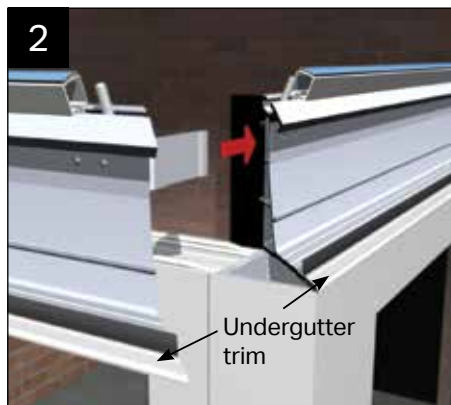

2 Place the next section of eaves beam into position, by slotting the corner cleat on the adjacent piece of eaves beam into the first piece.



3 Using the pre-drilled pilot holes, drill two 4.5mm holes through the corner cleats.



4 Securely fit the two M5 x 12mm taptite screws.

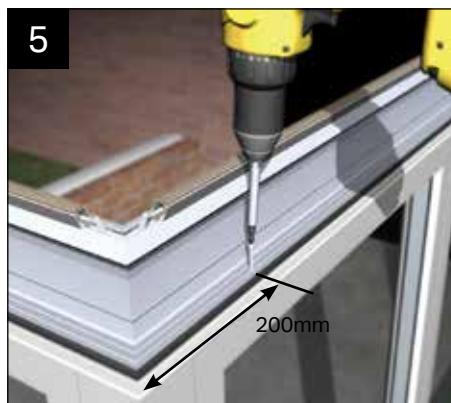

5 Securely fit the eaves beam to the frames using for example, 38mm x 4.8mm screws in the position shown. Fix down at 450 centres and within 200mm of each corner. For 60mm frames use the inner eaves extrusion line and outer line for 70mm frames. Always screw down. (Not supplied)



6 Once the eaves beam is secure, run a bead of silicone down the joint where the eaves beam sections meet and where the eaves abuts the host wall.

EDWARDIAN INSTALLATION

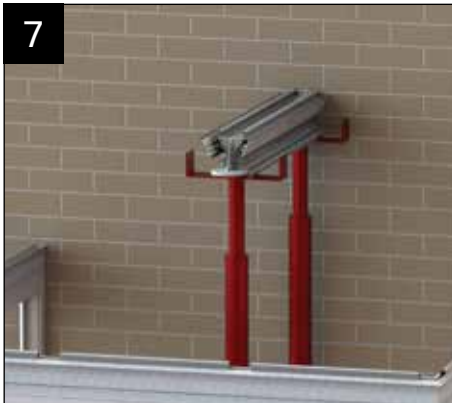

Support the ridge at the host wall and crown point. Ensure the spider has been pre drilled, glazing fascia and glazing pocket have been fitted.

Fitters Tip: Pre-stress the ridge by supporting it 10mm higher than specified at the crown point.



Offer up the first hip bar to the spider, insert the location pin through the spider arm fixed to the hip. Locate the pin into the pre drilled relevant hole on the spider.



Locate the hip onto the bolts at the eaves. Loosely secure with flanged nuts.

Repeat these steps until all hip and intermediate bars that meet the spider, have been positioned.



Continue to support the ridge and offer up the starter bars at the host wall.

Locate on to the single bolts at the ridge and eaves.



Secure with flanged nuts at ridge and eaves.



Continue to support the ridge and offer up the rafters that meet the ridge.

Locate onto the double bolts at the ridge and bolts at the eaves.



Secure with flanged nuts at ridge and eaves.



Using the location plan, repeat these steps until all rafters that meet the ridge have been fitted in the correct position and have been secured.



Fitting the jack rafters, ensure the jack rafter brackets have been fitted to the jack rafter prior to installation.

EDWARDIAN INSTALLATION



Offer up the jack rafter on to the hip and locate on the bolts at the eaves.
The jack rafter bracket should be angled towards the specified hip

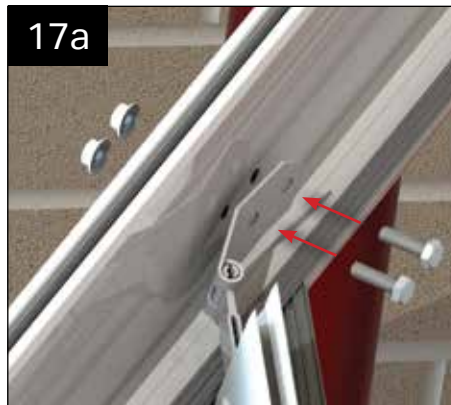

Align the bracket with the pre drilled holes on the hip bar, pass two M6 x 20mm through the holes and secure with flanged nuts.

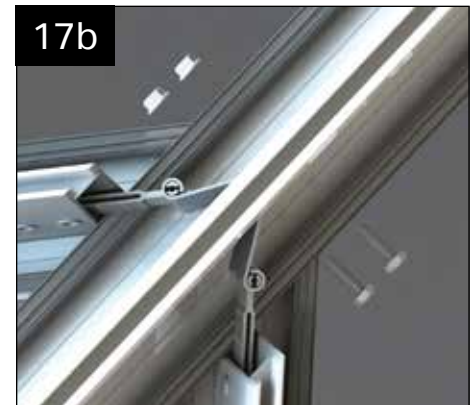

If two jack rafters are aligned either side of the hip, a M6 x 25mm bolt is required to fix both sets of brackets through either side.



Once fixed, minor adjustment maybe required to align the undercladding flush with the under side of the hip, this can be done by adjusting the bolts to suit.
Repeat these steps until all jack rafters are fitted. Fully secure all rafters and hips.

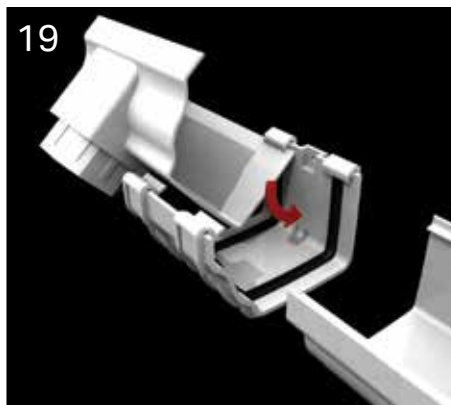

Next, build on the ground the gutter runs, by rolling items like a stop end under the back edge of a gutter jointer. Push up to the insertion line. **DO NOT** silicone seal, this would prevent natural expansion contraction.

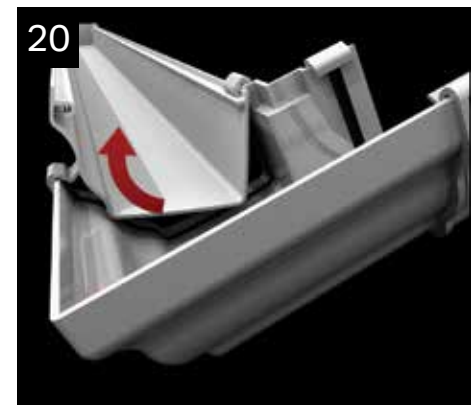

Snap the integral clips on the adaptors over the gutter. **IMPORTANT:** ensure all lengths of gutter fit to the market insertion line seen in all unions and box gutter adaptors.



Fit all the gutter brackets supplied with the kit at maximum 750mm centres and maximum 200mm from each corner.



Locate the back edge of each section of gutter into the slot in the gutter bracket.

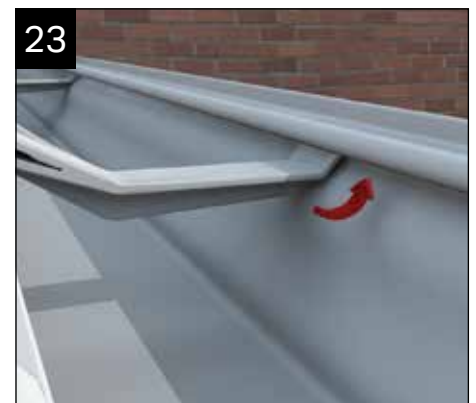

Clip the front of the bracket into the lip on the gutter. PVCu components like the gutter are easier to manipulate when warm. In cold conditions more 'force' may be required.

EDWARDIAN INSTALLATION



Ensure all gutter runs have been fitted and that all glazing bars are fully secured.

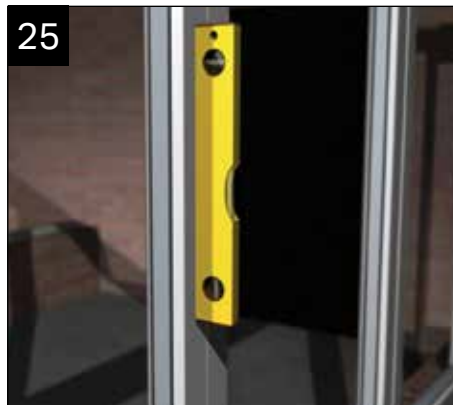

Check the window frames are plumb.



Ensure the ridge is level.



Check that the pitch of the roof is correct. Your Surveyor should have provided a drawing/a copy of the roof confirmation which displays the pitch.



Check that the starter bar and first transom bars are parallel.



Drill the starter bars/masonry within 200mm of the ridge and eaves beam plus at least one more equidistant between the two. Pack out to support the starter bar behind each fixing before fitting the correct masonry anchor.



Drill through the holes on the ridge fixing bracket and secure with the correct masonry anchor. **Now fasten the frames to the host wall and the dwarf wall.**

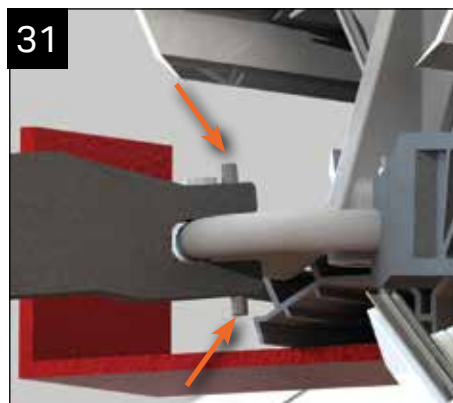

Tighten the grub screws on the spider arms to fully secure the hips at the spider. **(Minor adjustment can be done using the grub screws if hip bars are slightly uneven)**

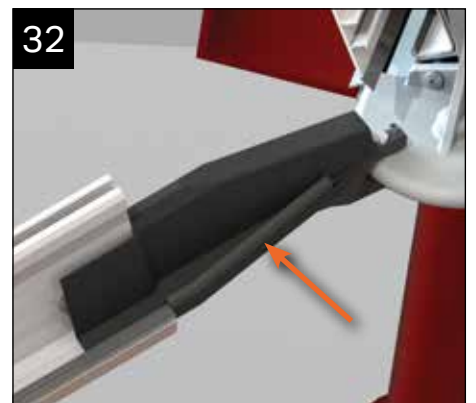

Fit the spider arm covers with the glazing seals inserted.

EDWARDIAN INSTALLATION

33

Now glaze the side frames before glazing the roof - this provides additional rigidity whilst working above. **INSTALL TIE BARS(S) BEFORE GLAZING.**

34



Take the glazing end profile and run continuous bead of sealant (appropriate for glazing) immediately behind the co-extruded gasket (along the full length). Now seal the space between the glazing end profile and the sealed unit (see inset) at each end (DO NOT DO THIS ON POLY ROOFS).

35



Snap off appropriate handed glazing stop. Place this into the base of the glazing bar.

36

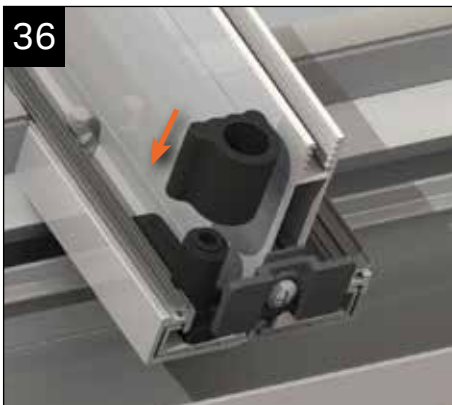

Snap off a grommet from the kit, this will slot over the upstand on the glazing stop.

Repeat steps 35 & 36 for all glazing bars on the roof.

37

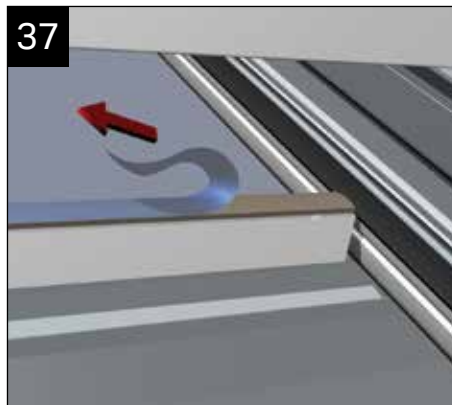

Tease the 'tail' of the glazing support trim tape free (ready to be pulled away when the sealed unit is finally in position).

38



At this point the roof should be glazed. Any ridge support may be removed.

Insert the glazing between the rafters ensuring that it is centralised.

If you are installing a roof vent please refer to page 14

39



Ensure the glazing stop is pressed tightly up against the end profile. When in position use the fixings provided to fix the glazing stop down into the bar as shown.

Ensure clip offers maximum support to glazing at all times.

40



Once the roof has been fully glazed and glazing stops secured, work your way around the roof fitting the glazing bar top caps. These should be angled in at the ridge first before forcing the top cap down along the bar length.

Ensure to fully engage anchor clip

41

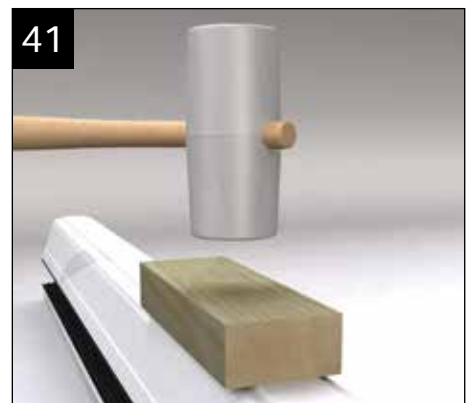

Knock the glazing bar top cappings on with a Deadblow hammer. Greater care is needed in cold weather. Keep all trims wrapped while fitting for protection.

EDWARDIAN INSTALLATION



If you haven't fitted already, attach end cap fixing brackets.
Fit the glazing bar end caps by sliding onto the end cap brackets. Push fit the insert into the end cap.



When fitting the jack rafter top caps, seal where the cap meets the hip top cap. The jack rafter top cap should sit tightly against the hip cap.

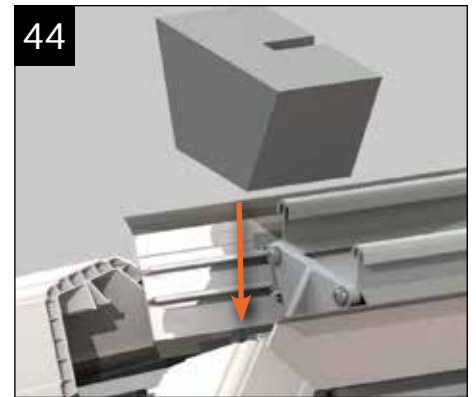

Once all the top caps have been fitted, insert the square foam block into the top of the crown point.

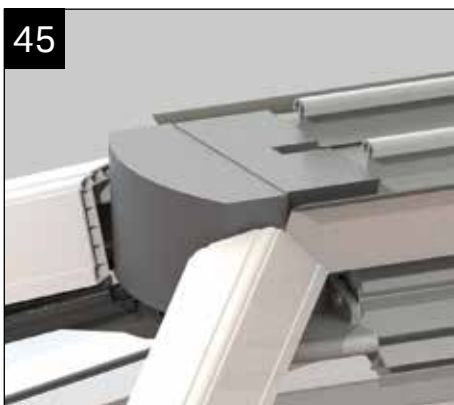

Take the semi-circular foam piece and insert it into the front of the crown point.
This may require sculpting to suit the situation.



Now fit the ridge flashing trim to the ridge top cap, apply a bead of silicone inside to secure.

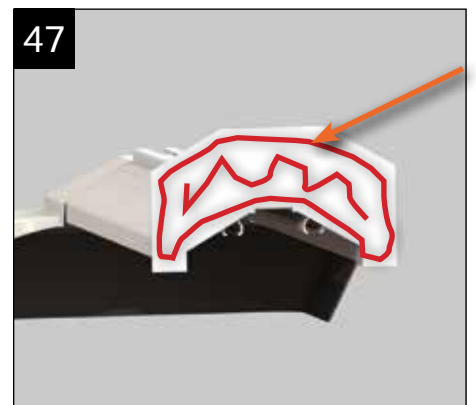

Apply a generous amount of sealant to the back edge of the flashing trim.



Fit the ridge top cap complete with flashing trim and crown cap to the ridge.



If cresting is specified, insert the cresting down the channel on the ridge top cap. This may require trimming to suit.



The finial should sit over the crown point when cresting is fully inserted.

EDWARDIAN INSTALLATION

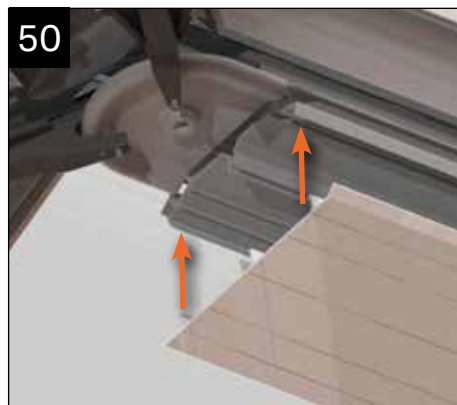

50 Moving inside the roof, fit the ridge undercladding to the ridge.

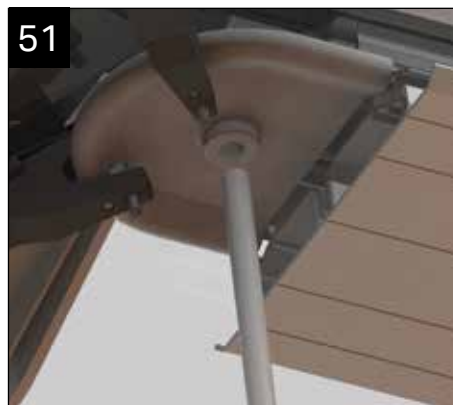

51 Insert the nylon threaded bar into the bottom of the spider.



52 Offer up the internal radius end cap, use the threaded bar and the retaining boss to secure the internal cap in position.
The threaded bar may require cutting to suit.

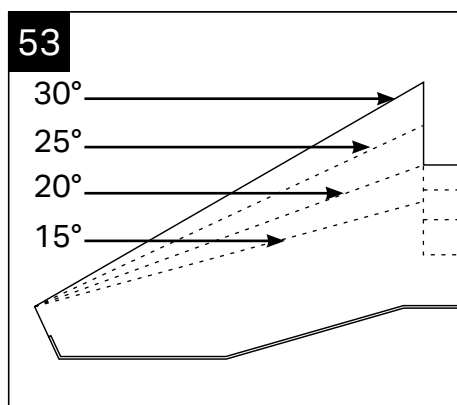

53 The internal radius end capping may require trimming to suit pitch (pitch lines are marked on the reverse of the internal radius end capping).



54 Fit the internal fascia claddings to the eaves beam, ensure the fascia corner packers are attached on the inside of the fascia at each corner.



55 Fit the corner covers by trapping them behind the fascia sections. Insert the circular infill to finish.

TIE BAR INSTALLATION

When a tie bar is specified, it is a structural requirement & must be fitted.

Prior to starting installation check the ridge is level and the side frames are plumb. THIS IS CRITICAL TO THE SUCCESS OF THE OVERALL INSTALLATION.

The position of the tie bar (s) will be indicated on the location plan provided whilst the tie bar brackets are already attached to the glazing bars.

Use this design when a tie bar and ceiling fan clash - two vertical drop rods.

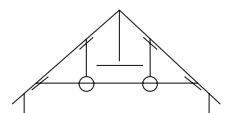

1a Tie bar at finial
Insert the tie steel rod thread into the base of the spider. Measure the drop of the rod and cut to suit the position or the tie bar boss ring.



2a
Offer up the internal radius end cap, retain this using the tie bar ridge fixing cover and two self tapping screws provided. Cut the PVCu conduit to suit.

SECTION 4

TIE BAR INSTALLATION

**Tie bar at ridge**

Mark the position of the where the tie bar meets the ridge, fix the ridge fixing cover using the self tapping screws provided.



Thread the tie bar rod into the ridge fixing cover. Measure the drop of the rod and cut to suit the position or the tie bar boss ring.



Measure, cut and attach the horizontal threaded bars (ensure sufficient engagement of the bar into the brackets) – it is essential that the tie bar boss is central. Take the boss ring, and loosely assemble the threaded bars to check they terminate inside the ring. Dis-assemble.



Insert the smaller diameter pieces of PVCu conduit inside. Offer into the boss ring and finger tighten the nyloc nut.

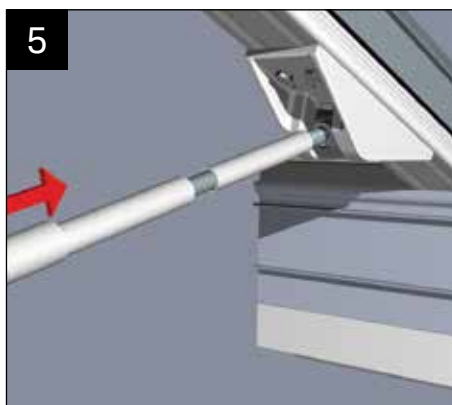

Offer up the horizontal pieces of PVCu conduit (large and small diameter).

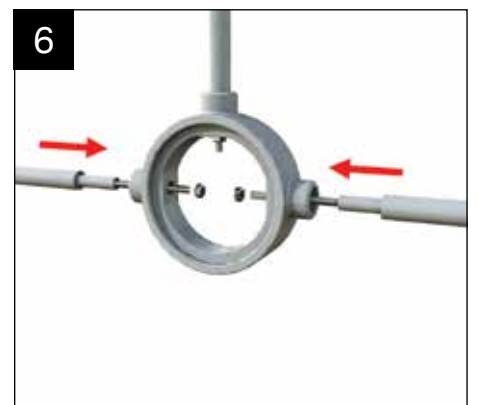

Insert threaded bar into the ring, and again finger tighten the nyloc nuts.



Now, finally check that the horizontal elements are level and the vertical element is plumb. CHECK THAT THE SIDE FRAMES ARE STILL PLUMB. Spanner tighten the boss nyloc nuts.

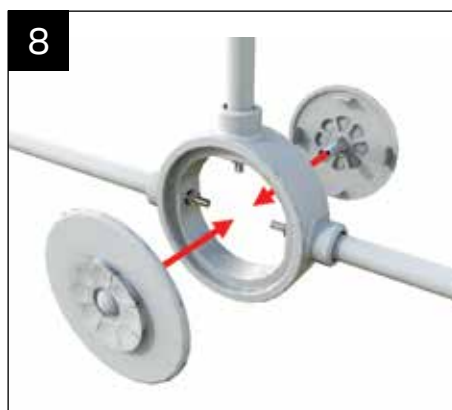

Offer up the two part rose cover, spin one half onto the threaded end of the other half.

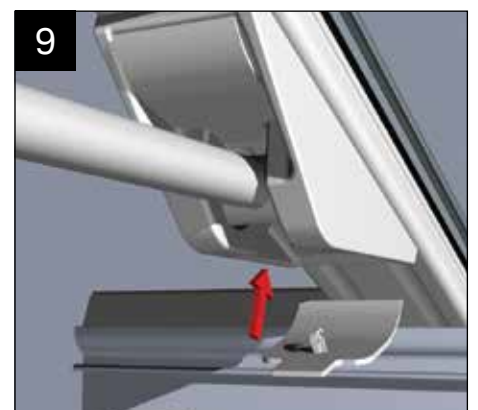

Attach the bracket cover plates that hide the bolts.

ROOF VENT INSTALLATION

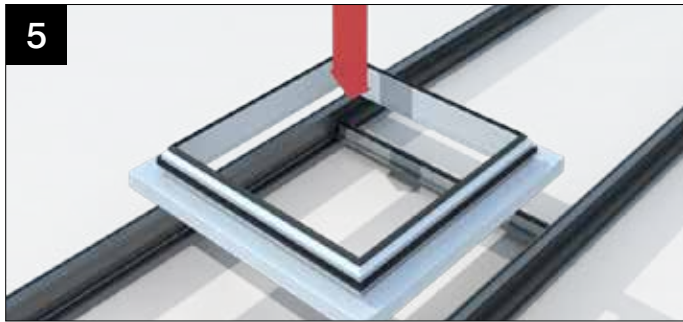

5 Peel back any protective film prior to fitting. Fit upper glazed unit and internal muntin bar. Carefully lower the vent frame into position onto the internal upper muntin bar.

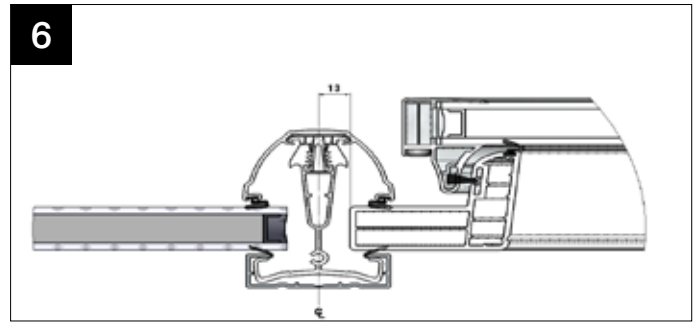

6 Ensure the vent is central between the transoms. As shown above there should be a 13mm gap between the bar centre and the frame. Use glazing packers if necessary.



6a If existing glazing is 32/35mm a packer will have been pre-fitted to the frame.

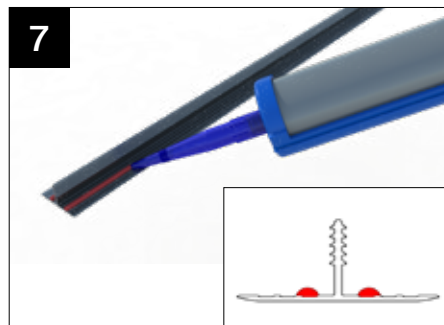

7 Run a bead of appropriate sealant ensuring a continuous run along the external upper muntin bar. Please see section view for bead positioning.

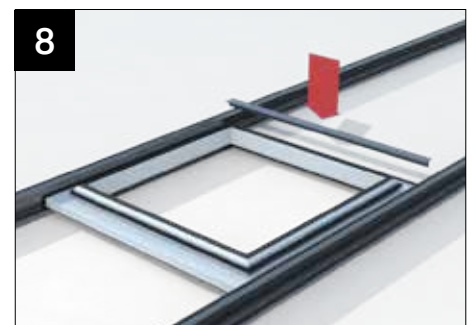

8 Locate the external upper muntin bar with the internal muntin bar, knock into place. The lower muntin may need to be supported from underneath whilst secure into final position.

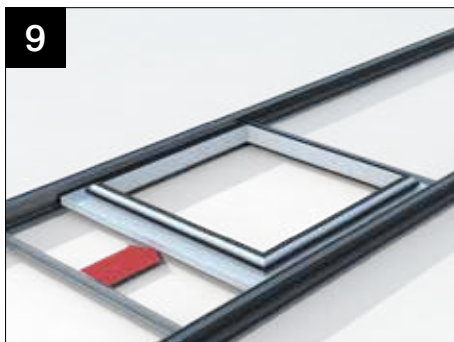

9 Slide the internal lower muntin bar into place under the vent frame. See cross section 9a for further detail.

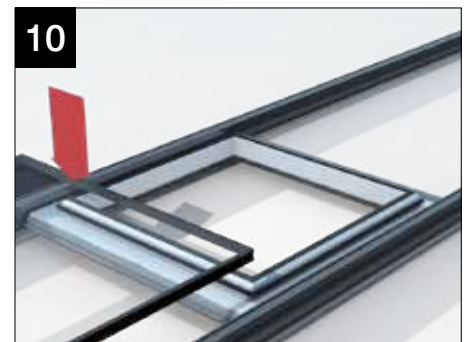
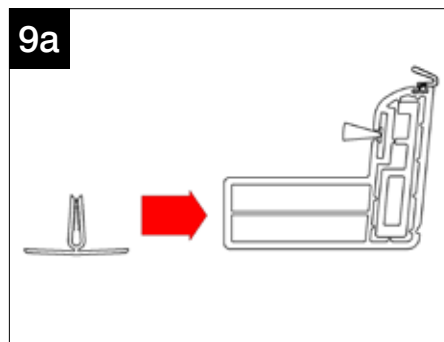

10 Remove any handling tape around the perimeter of the unit. Take care lowering the glazed unit into position on the internal lower muntin bar.

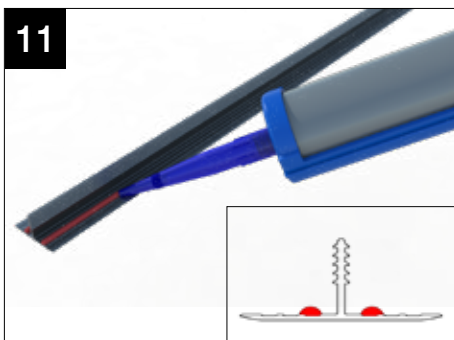

11 Run a bead of appropriate sealant ensuring a continuous run along the external lower muntin bar. Please see cross section for bead positioning.

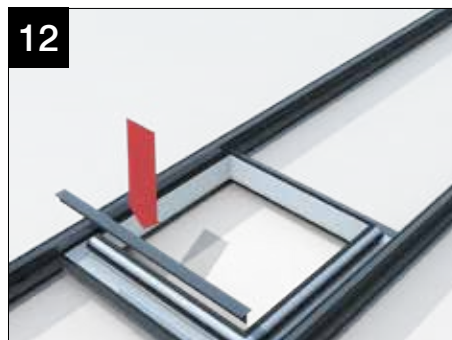

12 Locate the external lower muntin bar with the internal lower muntin bar, knock into place. The lower muntin may need supporting from underneath whilst secured into final position.



13 When the sealant on the mainframe has cured, re-fit the outer sash by holding vertically and re-engage on to the hinge, before lowering into position.

For more installation information, please refer to the roof vent installation guide which is supplied with the roof vent.

BOX GUTTER INSTALLATION

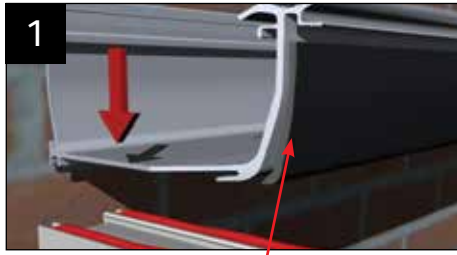

Box gutter foam to be cut back 70mm to enable the box gutter to sit flush on the frames.

Apply a continuous bead of appropriate sealant to the front and inner legs of the window frames. Lift insulated box gutter into position – ensure it has adequate support whilst fitting.



Either peel back or knife off a small amount of the insulation where the cleat is to be fixed. Drill a 4.5mm pilot hole and then fix the cleats with the two M5 12mm taptite screws provided. The protruding taptite screws will need trimming back prior to fixing the adaptor (alternatively, when its time to insert the adaptor, undue the taptites, drill a pilot hole through the adaptor and then re-screw the taptites and fully seal).



Now, from the bag in which the adaptor is supplied, take the special tube of sealant, Gutterbond. Apply a generous bead of it evenly across the mouth of the box gutter, 20mm back from the front edge.

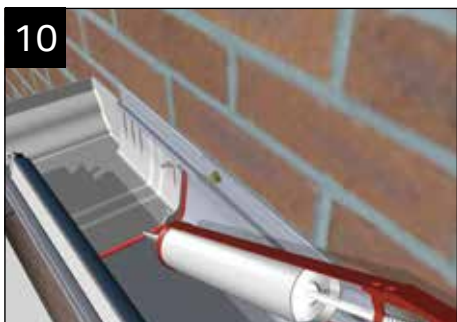

Use the balance of the Gutterbond to back point any gaps at the front edge.

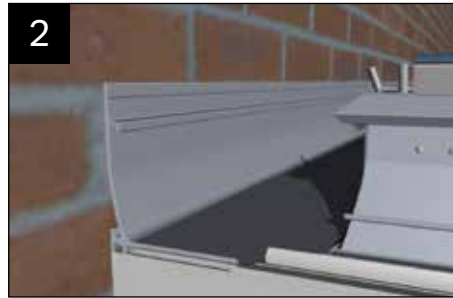

Place eaves beam section – with undergutter trim attached – onto the side frames. Seal the joint between the eaves beam and box gutter.

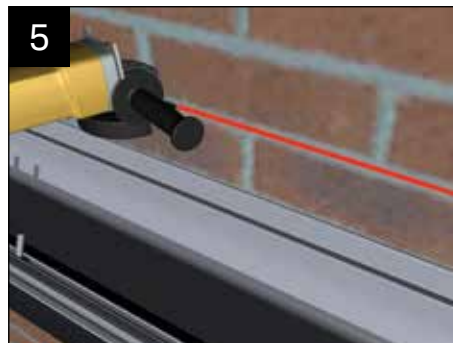

Mark out and grind a channel in the masonry for the flashing – blow out any dust in the channel.



Slide the adaptor into the aluminium box gutter, raising up its front edge to utilise the unique `snow plough` effect. This spreads the Gutterbond evenly under the adaptor. Push the adaptor firmly up to its end stop, so that it will line through with the Classic gutter attached to the eaves beam.

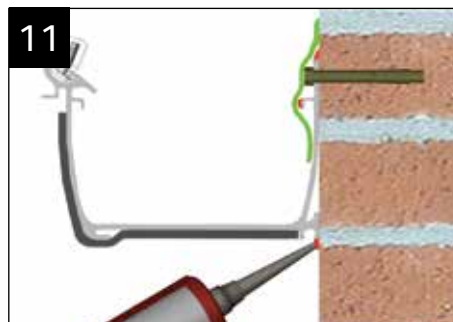

Seal the top and bottom edges of the aluminium box gutter, where it abuts the house wall.

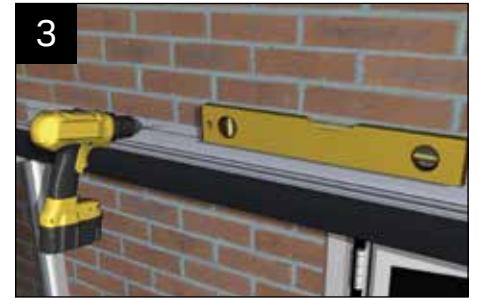

Whilst ensuring that its level, drill through the back edge of the aluminium at 600mm centres. Bolt to the house wall using masonry anchors that are suitable for the substrate.

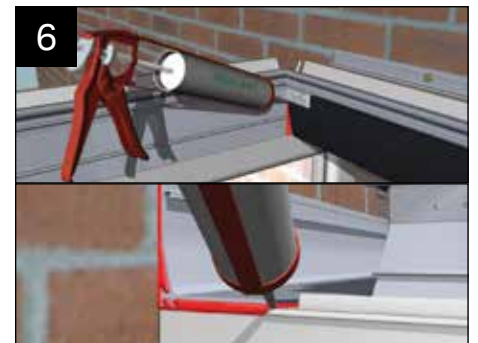

Now seal the internal joint between the eaves beam and box gutter and back point the leading edge of the box gutter where it sits on the side frames. Knife off a small section of the undergutter trim in preparation for the insertion of the adaptor.



With the adaptor tight to the end stop, turn the toggles upwards to firmly press the adaptor into the Gutterbond.

IN ADVERSE WEATHER CONDITIONS FIT THE ADAPTOR TO THE BOXGUTTER PRIOR TO LIFTING THE BOXGUTTER INTO POSITION

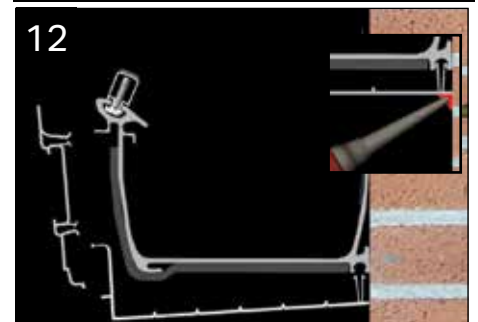

Before lifting into position, assemble the fascia board and undercladding. Offer up the undercladding rear legs, and knock up into position. Lastly locate the upper legs of the fascia board on to the box gutter. Finally seal the undercladding against the house wall.

BOX GUTTER JOINTING

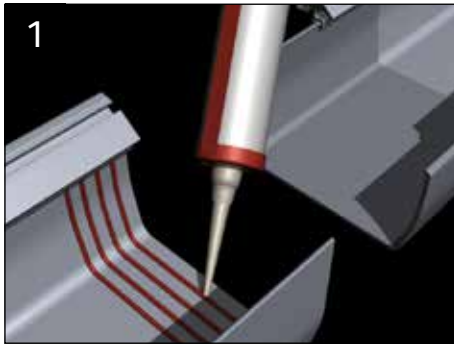

1
Thoroughly clean the mating parts using wire wool. Surfaces must be clean and grease free. Apply a generous bead of low modulus neutral cure to the pre-fixed internal sleeve along the entire face of the sleeve.



2
Drill through the top edge of the aluminium box gutter at 600mm centres. A fixing must be positioned within 50mm each side of the joint. Offer second half of the box gutter up to the internal sleeve and push firmly on. Fasten this second box gutter run to the host wall with masonry anchors suitable to the substrate. Ensure both sections are level and flush.

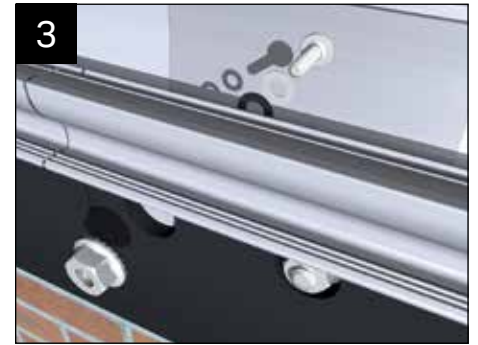

3
Drill 6.5mm holes through the box gutter and sleeve (at positions shown, ensuring both halves of the box gutter are flush together) and fix using the bolts, nuts and washers provided and in the order shown. Trim any excess off the bolt head before fitting the internal cladding as it may foul.



4
Check surfaces are dry, clean and grease free. De-grease if necessary. Heat both the sealing tape and the box gutter with a heat gun and position the tape over the joint. Press the tape firmly across the joint of the sleeve and the box gutter ensuring there are no air pockets.

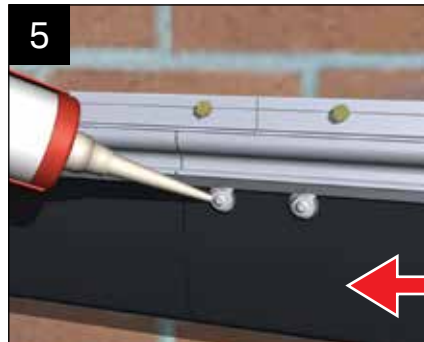

5
Now seal over all the exposed bolt heads, on the inside and outside of the box gutter.

ALL box gutters (especially those with tie bars or joints) MUST be supported.

We recommend several types of support for box gutters including brick piers. Fitting a conservatory box gutter without adequate support will lead to structural failure. Please take the correct steps BEFORE installation.

BOX GUTTER SUPPORT

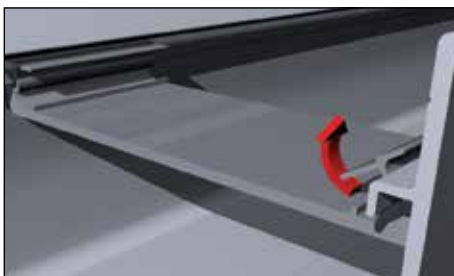

BOX GUTTER STRAP

165mm box gutters

These are supplied loose and **MUST BE FITTED** – they are a structural requirement of the roof. The straps must be installed within 75mm of glazing bar centres (when measured from centre of the strap to the centre of the bar). To install these straps, simply `nip up` as shown.

265mm/special box gutters

Straps are factory welded into position.



GALLOWES BRACKET

These are available for 165/265 box gutters.

To install, notch out the insulation to ensure metal to metal contact between the extruded box gutter and gallows bracket. Offer up the gallows bracket and mark it ready to drill – always try to line up with the centre of a brick rather than a mortar joint. Drill the gallows bracket (the positions should be similar to the ones shown). Three masonry anchors should be used that are appropriate to the substrate.

Finally, notch out the undercladding, offer it into position and clip in.

Maximum centres are 2300mm. If the roof has a tie bar installed or a joint within the box gutter, then a gallows bracket should be installed directly underneath it.

BOX GUTTER SUPPORT



BOX GUTTER HANGER

165mm box gutters

If these have been specified by your company at the time of order they are supplied loose and must be fitted.

The structural requirement for the hanging brackets are 2 x hanging brackets (sat side by side) at a maximum span of 2300mm unless the roof has a tie bar or joint on the box gutter which should then be positioned in the same area.

Drill through the head of the hanger into the centre of the masonry, avoiding the mortar joint if possible. Use a masonry anchor suitable for the substrate. Lead flashing should be dressed down over the hanger, and snipped around the sloped leg. To attach it to the box gutter, simply 'nip up' as shown.

265mm box gutters

Hanger not available.

RAISED BACK BOX GUTTERS

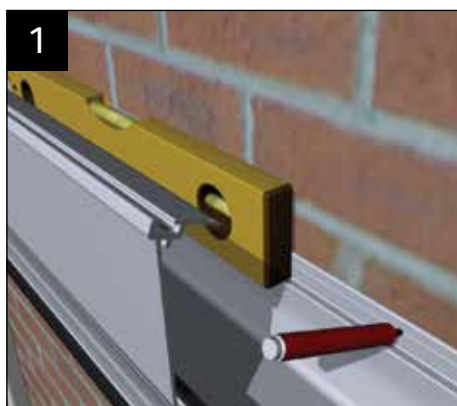

Offer the raised back or special box gutter into position. Carefully mark onto the aluminium leg against the host wall the position of each fixing – use 600mm maximum centres.

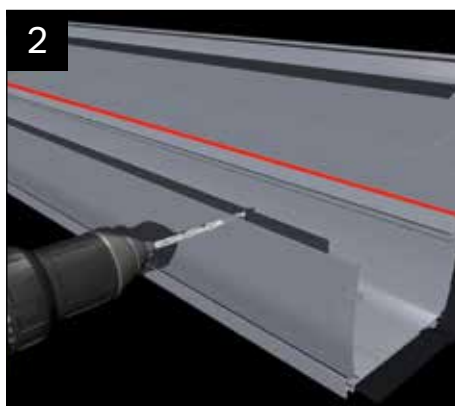

Lift the box gutter down to the ground and turn it around. Drill through the aluminium leg (that abuts the host wall) at the pre-marked positions. Whilst the box gutter is on the ground, seal along the front/rear face where the deep skirt sits inside the head of the extruded box gutter. (Highlighted in red)



Lift the box gutter back into position, check levels, and then mark the wall (through the pre-drilled holes) ready to drill the host wall and grind out for the flashing.

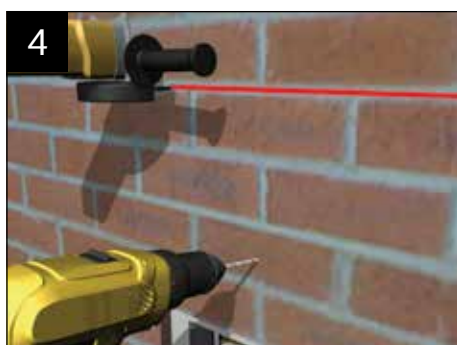

Remove the box gutter and drill the host wall where marked. Grind out the course which is at least one course higher than the raised back height.



Offer the box gutter into position and insert the anchor fixings that are appropriate for the substrate and tighten up.

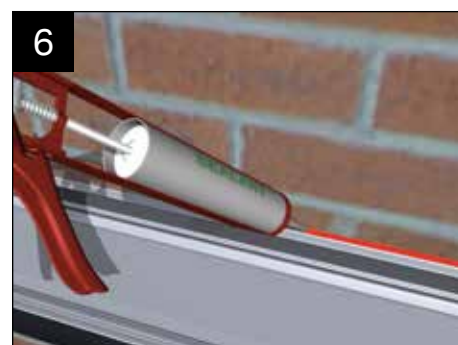

Seal the top and bottom edges of the box gutter and follow all other steps as per standard box gutters on page 20-23. When installing the lead flashing, ensure that the top of the flashing is higher than the point of rain water discharge from the glazing bars. Clad off the deep skirt of the raised back box gutter using multi-board (not supplied).

VALLEY INSTALLATION

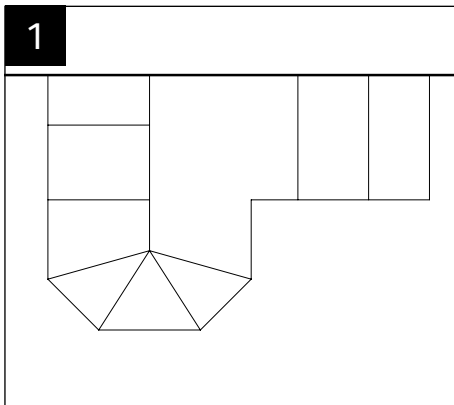

At the stage where all other bars have been fitted and secured to the roof and the ridge and half ridge have been fixed to the wall, the valley assembly should be fitted.



Ensure the two ridges are at the correct height and are level. Make sure bolts at the ridge and eaves have been fitted to accept the valley.



Offer up the aluminium valley section, ensuring the under cladding location barbs are slid into position. Locate onto the captivated bolts in the ridge, half ridge and eaves beam. Secure the valley using the 4 spigot nuts provided in the valley end cap kit.

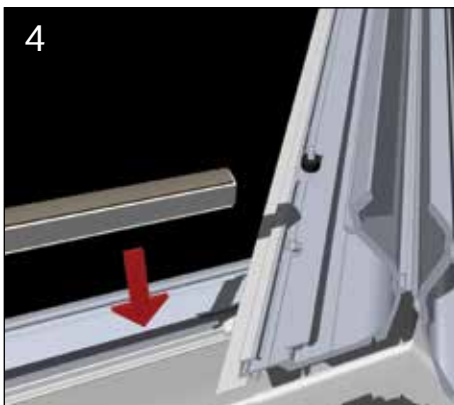

Cut and re-fit the glazing support trim, where the valley meets the eaves beam.

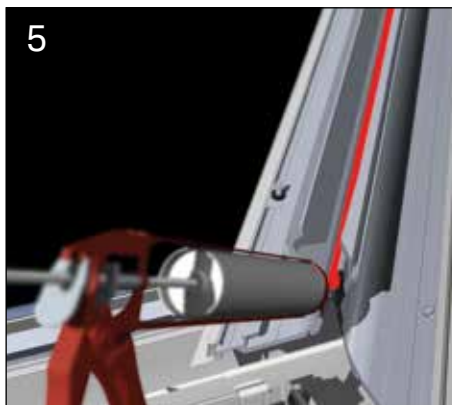

Now run a continuous bead of suitable silicone down the entire length of the aluminium valley profile, at the point of the hinged connector in the centre.

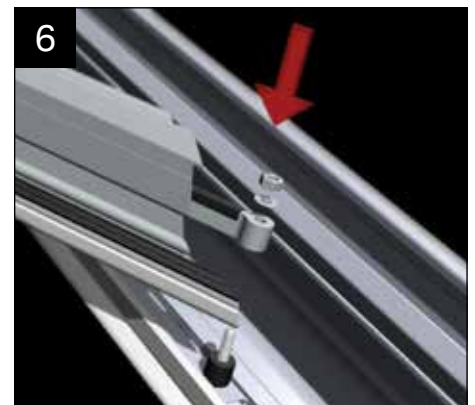

Using the location plan provided, assemble the various valley rafters onto the valley. Use the washers and nuts provided to ensure a robust joint is created.

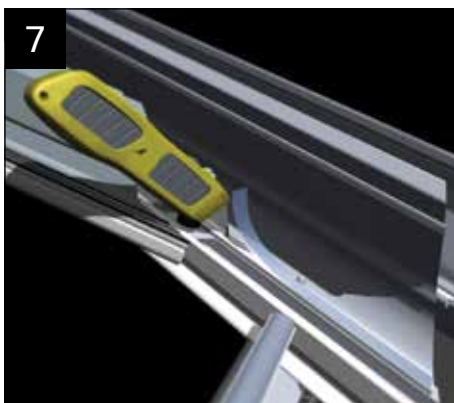

Fit the double sided sealing tape to each of the valley wings. Tease one end of the protective tape loose, crease it about 50mm in from the end and fold over ready to extract once the glazing panels are laid in position.



To retain the glazing to the valley wing, fit 2 wire clips (100mm from each end of the profile). The hooks locate behind the lip detail as shown. Apply a continuous bead of sealant (MS Polymer to self cleaning glass).

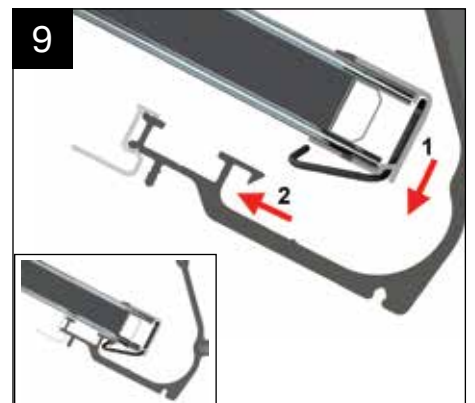

Place the glazing in its correct position. Position the end profile down into the valley as shown. With the glazing pressed flat against the valley profile and your fingers underneath, pull the glazing up into the rain baffle and allow the clip to 'lock' the glazing in place. Once properly fitted, the clip should lock into place as shown.

VALLEY INSTALLATION

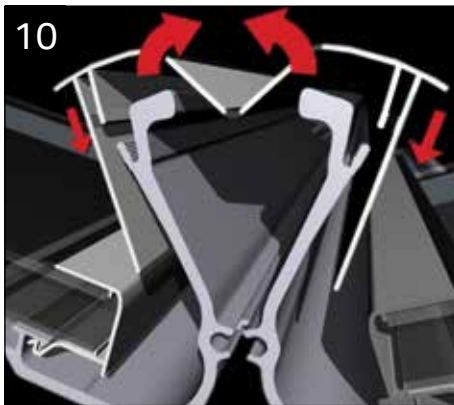

Fit the valley top cladding by folding to form an internal 'V' - then tap into the aluminium valley profile using a plastic hammer.

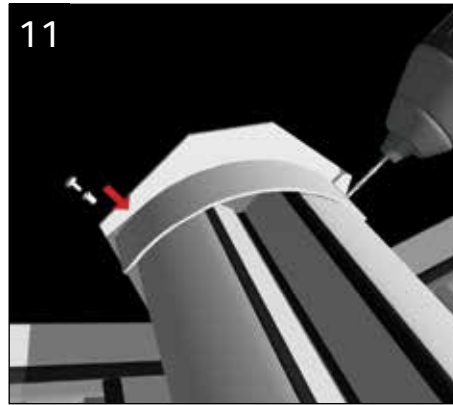

Fit the valley end cap using the two plastic rivets supplied or appropriate fixings.

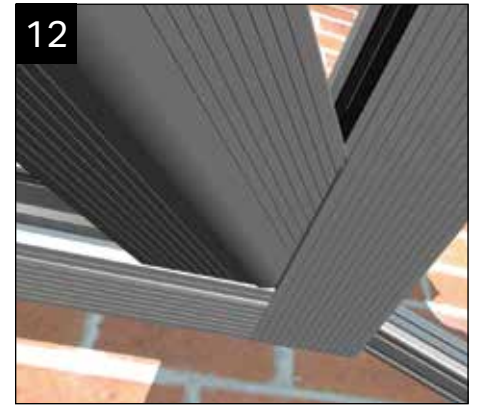

Finally fit the valley under claddings, these may require scribing to suit.

LEAN-TO INSTALLATION

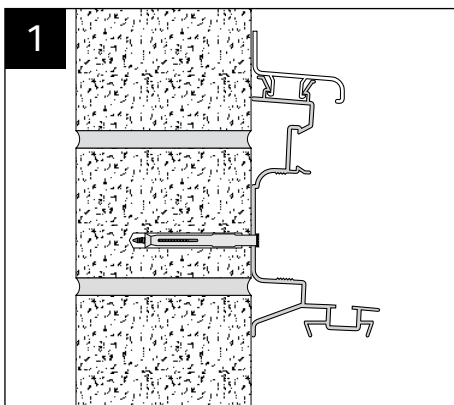

Fix the ridge at the specified height to the wall, drill through the v groove behind the glazing pocket.

If the wall is uneven, packing may be required behind the half ridge.



Ensure all the captivated bolts have been fitted, glazing pocket and ridge fascia.

Offer up and secure the rafters on the bolts at the eaves and ridge. Secure with flanged M6 nuts.

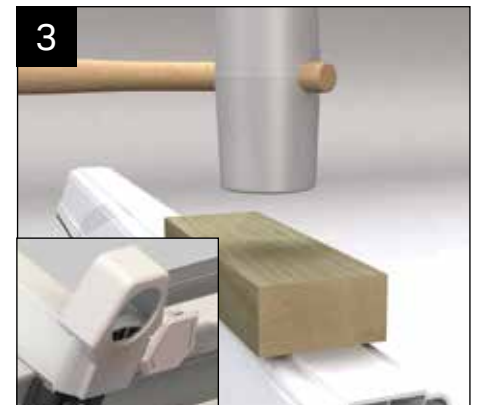

Now glaze the roof, fit the rafter top cappings and the rafter end caps.



Fit lean to ridge top and bottom caps.



Apply silicone to the gable side cappings and fit to the gable bars. These may require cutting in for a low pitch ridge.

TIP: Screw the side capping to the gable bar at the top and bottom where the screw will be covered by the end caps.



Apply silicone to the inside of the ridge end cap where it contacts the ridge top cap and the gable side capping.

Ensure the lead is flashed over the ridge end caps.

GABLE INSTALLATION

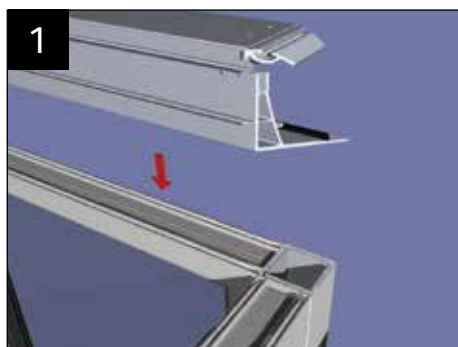

Trial fit the gable beam and the eaves beam ensuring the inside face is flush with the inside face of the window/door frames. Remove, then apply a continuous bead of silicone to both the front and rear edges of the window/door frames.

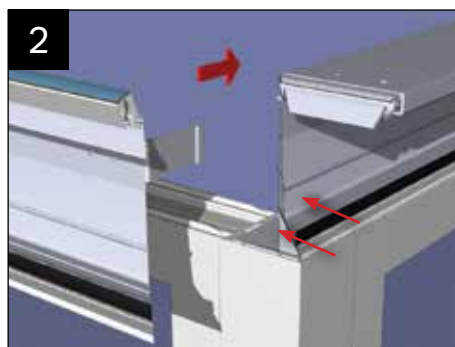

Fit the under gutter trim to each section of eaves beam and gable beam, position the beams and slide the corner cleats (already attached to the eaves beam) into the gable beam. Drill through the holes already in the gable beam into the cleats and secure with the screws supplied.

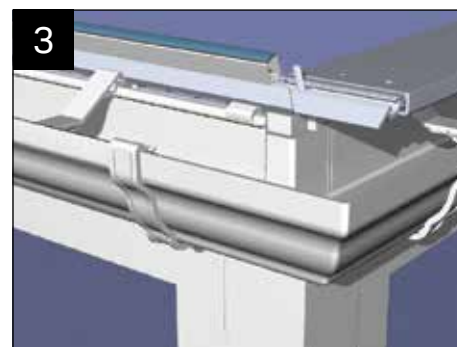

To secure the gable beam (see Vic Fixing Kit page 8), then at this stage the guttering is installed. First attach the gutter brackets to the gable/eaves beam. Fit the 90 degree external gutter corners to the gable beam length of gutter. The brackets are at maximum 750mm centres and 200mm from each corner.



With the guttering in place, trim the gable beam top cladding. The cladding is supplied over length and cut to suit the roof pitch (see table).

Roof Pitch (°)	Dim A (mm)
10	83
15	85
20	87
25	89
30	93
35	98
40	104

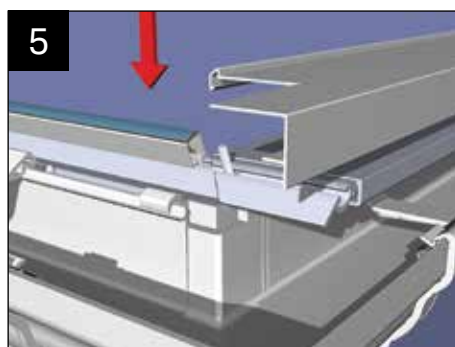

Next attach the notched gable beam top cladding on to the head of the gable beam.

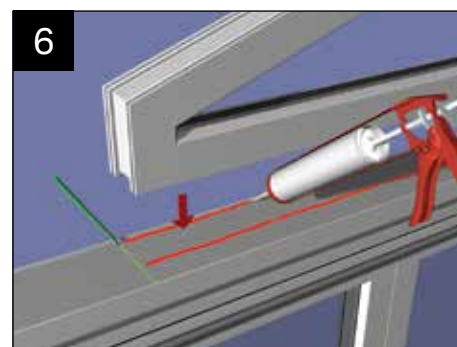

Position the gable window frame central to the gable beam, and mark the position. Remove the frame and again run two beads of silicone along the head of the gable beam top cladding (the width of the window frame only). Replace the frame centrally and back against the upstand of the gable beam top cladding. Fix securely through the frame into the head of the gable beam with self tapping screws (not supplied).

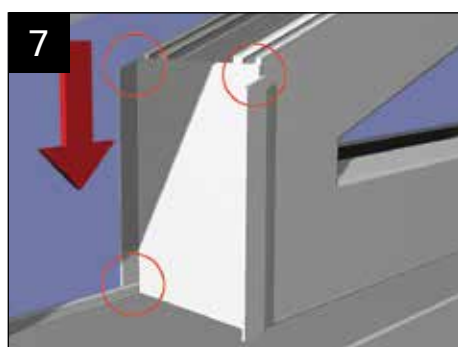

Mark and cut the gable infill end cap. Notch inner bottom edge to allow the end cap to sit flush and tight to the gable window frame. Trim top edge to suit pitch of roof and gable frame firing top cap which should be placed into position for marketing purposes.

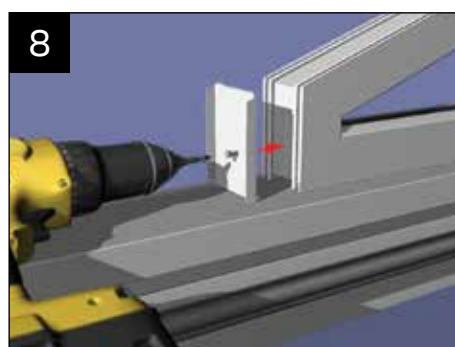

First silicone and then screw the end cap to the gable frame.



Trial fit the gable infill wedge. Remove, run two beads of silicone and place back in position, tight up against the infill wedge end cap.

NOTE: it will be necessary for non standard pitches to trim the infill wedge to suit the pitch, maintaining the 135mm height dimensions.

GABLE INSTALLATION



Place and support the ridge ensuring the ridge is central to the gable frame. Place the starter bar onto the frame and secure to the ridge and eaves beam. Securely fix the starter bars to the gable window frame. Fit and glaze the roof in the normal manner. **NOTE: Ensure the gable frame is vertically plumb.**



Offer up the gable side cappings, insert these onto the hooks on the gable bar. Scribe at the eaves end against the gable beam top capping. **Fit the ridge top cap if not done so already.**

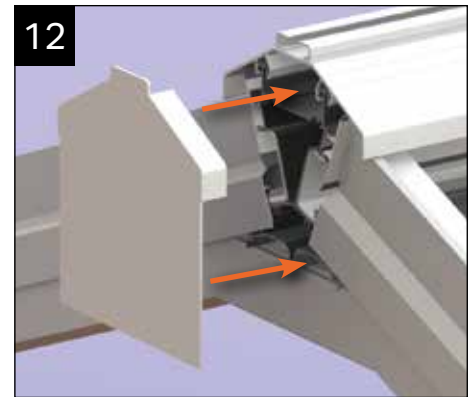

Apply silicone to the inside of the ridge end cap where it contacts the ridge top cap and the gable side capping.

HIP LEAN-TO INSTALLATION

SECTION 10



Follow the lean to installation steps on **P19**. Ensure the half spider has been fitted as well glazing fascia which should extend 70mm past the end of the ridge at the spider.



Once all rafters have been fitted to the ridge, fix the starter bar, with the spider arm attached, to the wall whilst secured at the eaves and spider.



Then fix any other hips that may be present and secure to the spider and at the eaves.



Offer up the half internal crown cap so that the skirt touches the bottom of the rafters. When in position screw to the host wall



Once the roof has been glazed and the glazing bar top caps have been fitted, insert the foam at the crown point. Fit the ridge top and bottom caps. (Cut the foam to suit the situation).



Fit the half crown cap, apply silicone to the ridge top cap where the crown cap overlaps. Secure fix with poly top screws. Notch the skirt of the crown cap to accommodate the rafters present. **The lead should be flashed over the crown cap.**

MUNTIN BAR INSTALLATION



IF YOUR SEALED UNITS HAVE BEEN SUPPLIED WITH TAPED EDGES, ALWAYS REMOVE THE TAPE PRIOR TO INSTALLATION. Take the muntin bar profile (top and bottom section) that matches its corresponding sealed unit. Take the lower section and allow it to span between the two adjacent glazing bars. Lower into position the up slope sealed unit. NOTE: MUNTIN SHOULD BE SAME WIDTH AS UNIT.



Now take the upper section and lay it face down onto a smooth clean surface. Using the relevant sealant (MS Polymer sealant such as Rotabond 2000 must be used on self cleaning glass), apply a generous bead to each side, immediately behind the gasket.

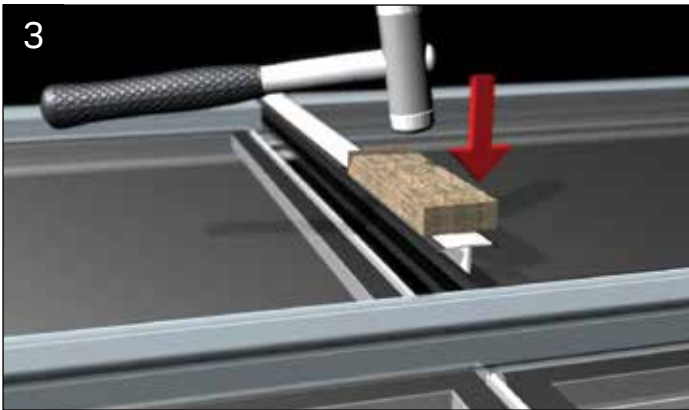

Now lift the sealed unit that goes on the lower slope into position, turn the upper profile over, place it into position and tap down the profile using a non marking plastic mallet. Wipe clean any sealant from the unit face. NOTE: WE RECOMMEND A SECOND PERSON TO SUPPORT THE MUNTIN FROM THE UNDERSIDE WHEN TAPPING DOWN.



Now, tap the PVCu top cap into position, which will 'trap' the muntin profiles.

CAPPING REMOVAL



Insert the capping removal tool as shown.

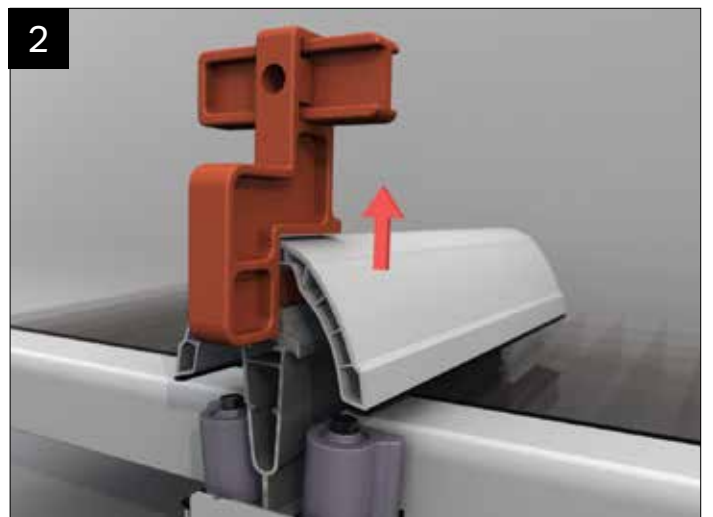

Lift the capping removal tool up, releasing the top cap legs from the aluminium.

GUTTER COVER INSTALLATION

Ensure the eaves beam, glazing bars, ridge/wallplate are already installed



1
Decide the position of the gutter outlet by lining the extrusion 'v' groove up with the centre of the hole for the down pipe. Using a 73mm dia hole saw, cut the hole for the down pipe in the lower section.



2
Remove the under gutter trim and dispose of it. Prior to fitting gutter offer up the lower section then secure into position using the fixings provided (CRN007). **Please note: Always start with the front facet!**



3
Fit the cleats (CRN001) to the desired side using the fixings provided (CRN006) as shown and assemble the remaining lower sections.

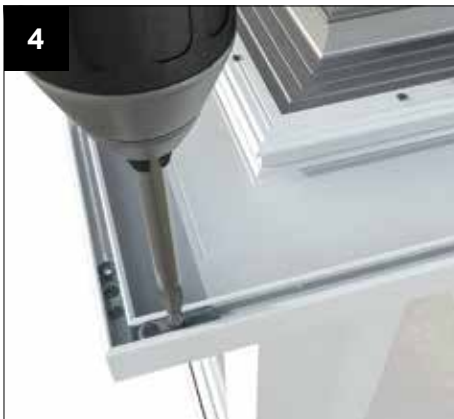

4
Secure each corner using the cleats (CRN001) and fixings provided (CRN006).

The gutter and glazing should now be fitted (see main guide). Check integrity of all gutter joints before proceeding further.



5
Offer up the middle section into position, (it may be advisable to temporarily support the lower section whilst fixing) secure using fixings provided (CRN007). (Long reach driver required).



6
Fit cleats as shown in step 3. Offer up the next middle section. Continue to support lower section as shown in step 5.



7
As shown in step 5 it may be advisable to temporarily support the assembly whilst fixing. Secure corners using the cleats (CRN001) and fixings provided (CRN006).



8
Clip fit the support brackets (CRN002), adjacent to every gutter bracket.



ADDITIONAL STEPS

Ensure the eaves beam, glazing bars, ridge/wallplate are already installed

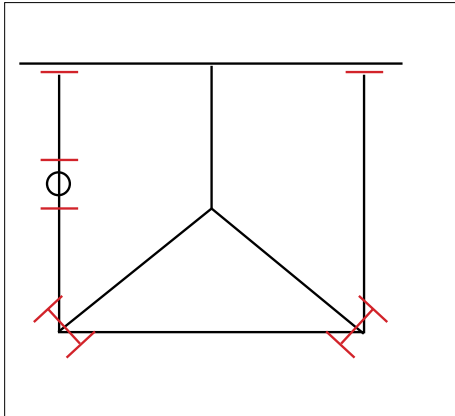

'H' or '-' shows position of DAMS.

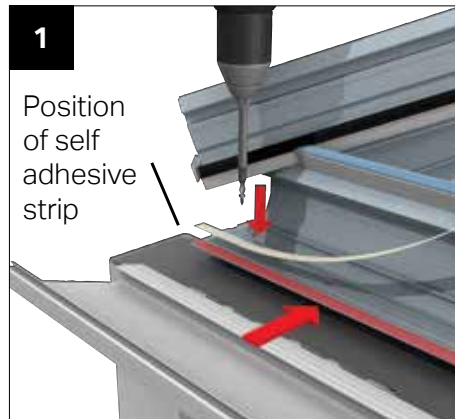

Remove under gutter trim, attach self adhesive strip to 'toe' of eaves beam.



Silicone seal front and back edge of lower sections (be generous). Similarly butter 'DAM' sealer - position within 50mm of any stop end or outlet.



Take 'rubberized' sealer strips and generously butter with silicone.



At 90° corner insert 'H' section and press down. Similarly apply at stop end or outlet positions.

GUTTER COVER INSTALLATION - TOP SECTION

Ensure the eaves beam, glazing bars, ridge/wallplate are already installed



1
Temporarily support and fit the upper section, using the fixings provided (CRN007).



2
Secure the corners using the cleat (CRN001) and fixings (CRN006).

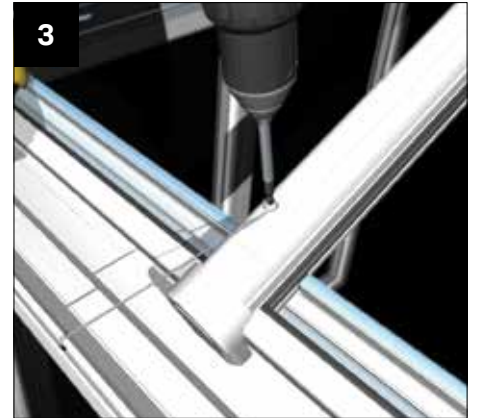

3
Secure the upper section using the wire ties at each glazing bar. Hook the wire tie into the pre-drilled hole in the upper section and screw fix into the glazing bar, ensuring the upper section remains parallel to the frames/roof line.

GUTTER COVER INSTALLATION - CORNER SECTIONS

90° Corner (no columns)

CRN090

90° Corner (small columns)

LRP022

90° Corner
(large columns)

LRP021

135° Corner (no columns)

CRN135

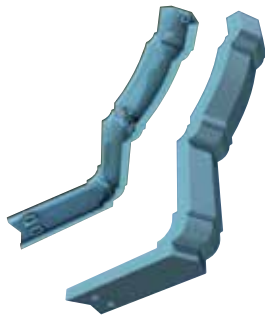

Long Corner Wire Tie

CRN012

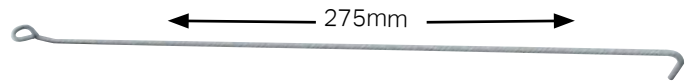

Fixing Screw

CRN010 (Wire tie to hip bar)



Fixing Screw

CRN007 (2 per corner)



Please note that it is not compulsory to fit the corners. If a crisp sharp mitre is required the corners need not be fitted, provided due care has been taken during installation. If on the other hand the 'look' of the cast corner is preferred follow the instructions above for each relevant corner. Corners will be supplied for the 135° & 90° external corners.

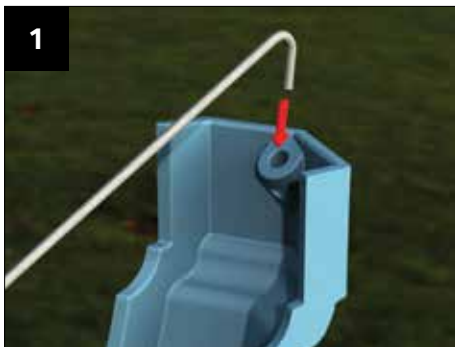

1
Prior to fitting the corner insert the special longer wire tie CRN012, into the corner as indicated



2
Whilst ensuring that the corner remains located in position, screw fix using self drilling screws CRN007



3
Finally secure the corner by screw fixing the wire tie to the glazing bar using self drilling screw CRN010

CURVED INLINE INSTALLATION - JOINTER SECTIONS

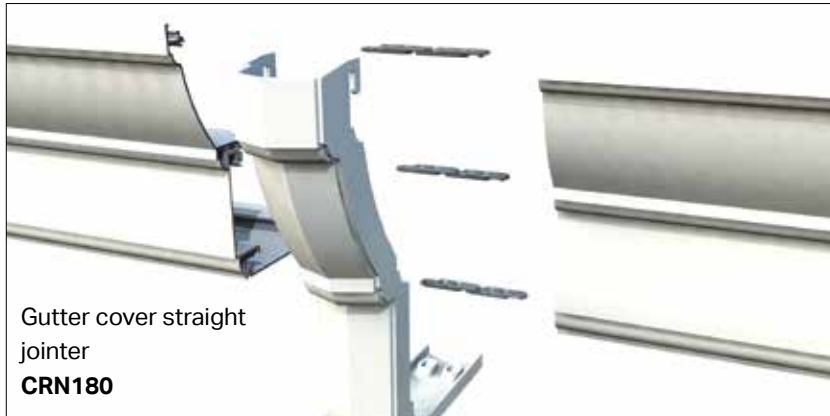

Cleat
Fixing Screw
CRN006
(2 per jointer)



Cleat
CRN001



Fixing Screw
CRN007 (2 per jointer)



Please note that it is not compulsory to fit the jointers provided. If due care has been taken with the installation of the gutter cover. If on the other hand the 'look' of the cast jointer is preferred follow the instructions above for each relevant jointer. Some companies MAY have ordered a 'dummy' joint at 'mid-run', if so just follow steps 2 + 3. The die cast straight jointer can also be configured on site to be used at host wall position.

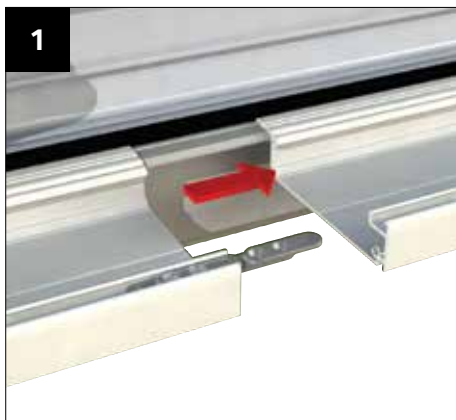

1
Attach the cleat CRN001 using 2 x CRN006 provided, on each side of the joint. Repeat for each of the 'layers'.

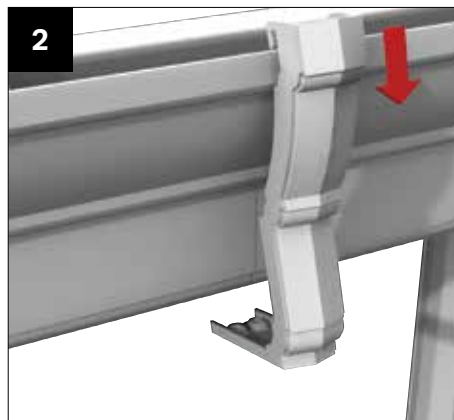

2
Offer up the CRN180 straight jointer, hook over the front lip of the gutter cover.

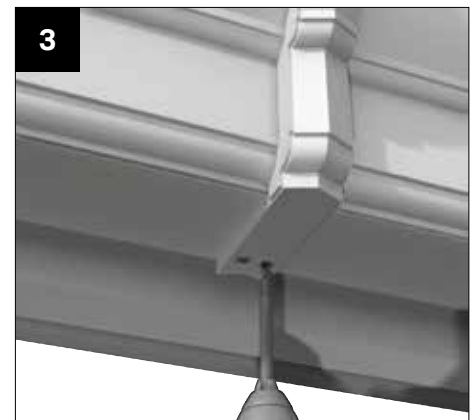

3
Whilst ensuring that the inline bracket remains located in position, screw fix using self drilling screws CRN007.

GUTTER COVER INSTALLATION - ADDITIONAL DETAILS



1a
GUTTER RETURN DETAIL - If the gutter returns along the host wall (shown above) complete steps 1A and 1B after step 4 of the general installation.

Ensure the treated timber baton (49mm x 20mm) is level, then fix into position.



1b
Secure lower section using fixings provided (CRN007)

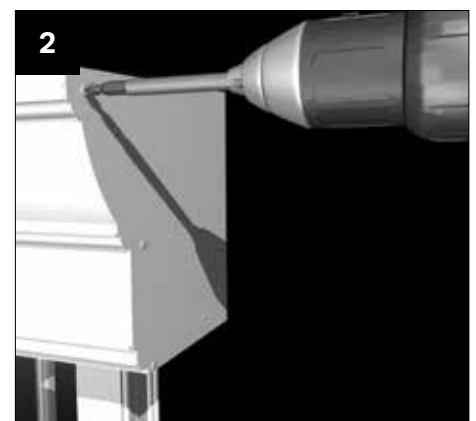

2
GUTTER STOP END DETAIL - Used with lean-to roofs, gable roofs or when the gutter returns along the host wall.

Secure the end plate into position using the fixings provided (CRN008).

DECORATIVE FASCIA INSTALLATION - ADDITIONAL DETAILS

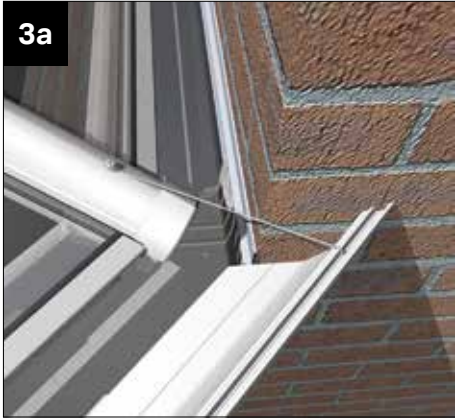

3a
GUTTER COVER & VICTORIAN BOXGUTTER DETAIL - For situations other than that shown, gutter cover should be prepped by you on site to suit the wall condition you find.



3b

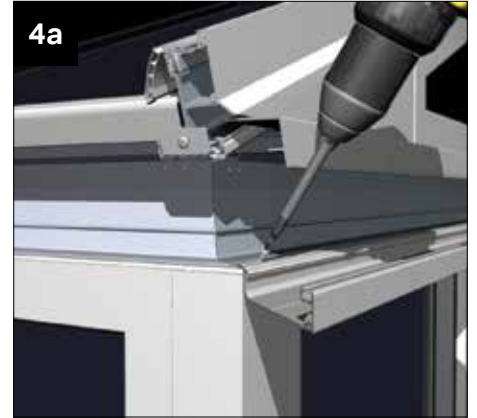

4a
GUTTER COVER & GABLE EAVES BEAM DETAIL - Used on lean-to styles with raked frames or duo-pitch gables that use the gable support beam. Fix lower section as shown - continue with the remainder

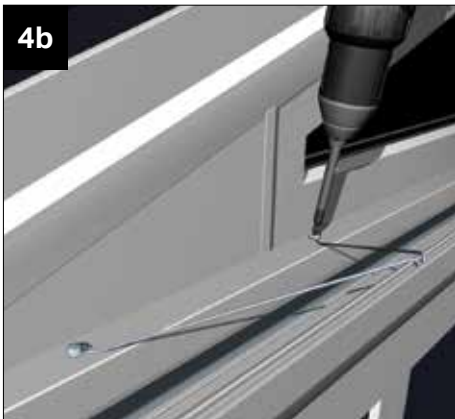

4b
Fix wire ties at an angle as shown, ensure the gutter cover is parallel to the frames/roof line.

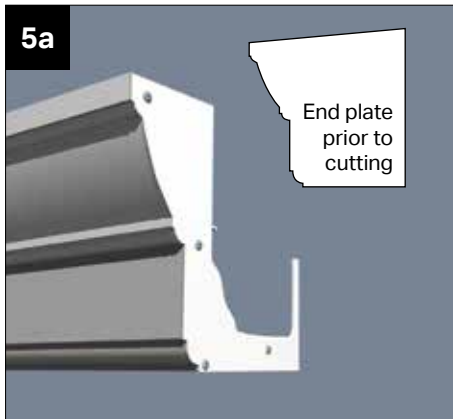

5a
GUTTER COVER & FLY THROUGH GUTTER DETAIL - Used when the gutter extends beyond the gutter cover. Take the end plate (CRN003) and cut to the shape of the gutter that projects beyond the gutter cover.

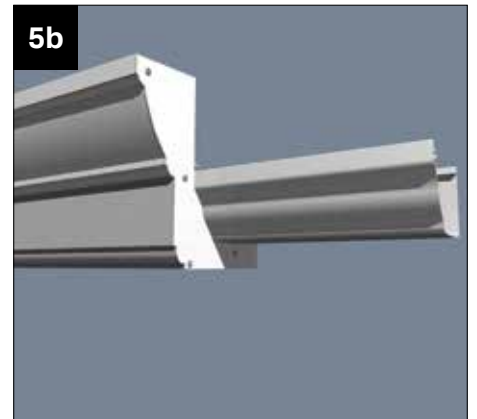







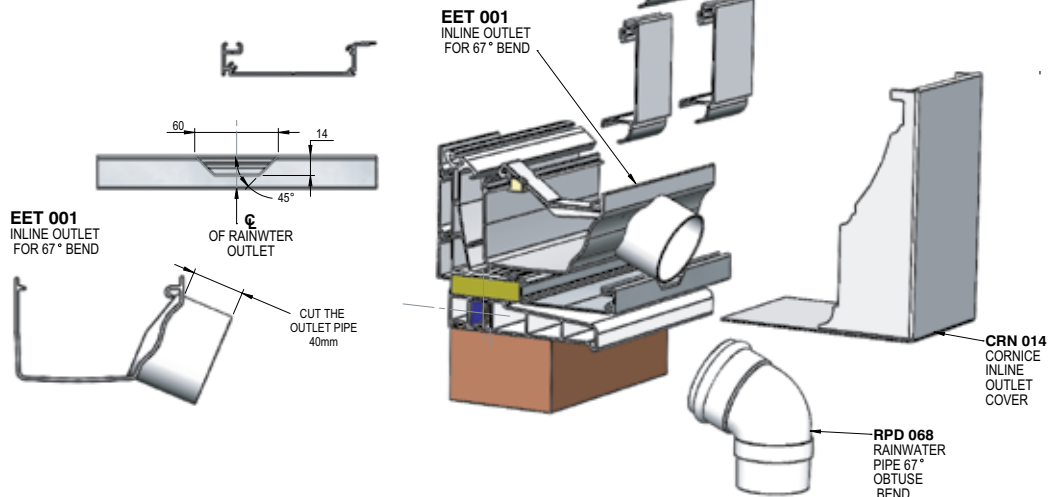
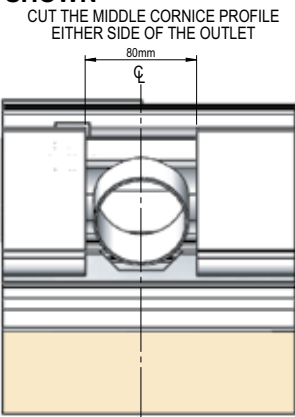



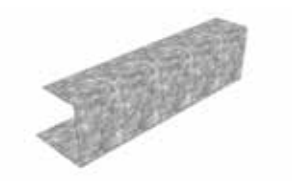
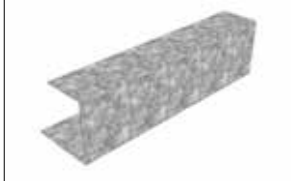
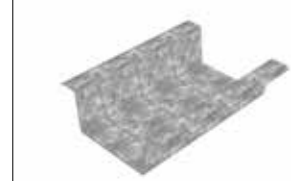







Typical finished detail.

GUTTER COVER INSTALLATION - INLINE OUTLET COVER

IT IS IMPORTANT TO CONSIDER THE OUTLET POSITION PRIOR TO FITTING THE GUTTER COVER. WHEN THE OUTLET POSITION HAS BEEN DECIDED NOTCH THE GUTTER COVER LOWER PROFILE AS SHOWN



INTERNAL PELMET INSTALLATION

			
CHA405/1 Perimeter Channel - PIERCED	CHA405/2 Perimeter Channel	CHA405/3 Crossrail Channel	Bolster Corner Infill
			
CHA001 Transom Bracket	CHA090 Georgian Hip Bracket	CHA003 Hip Bracket Adjustable	CHA011 Splay Bar Bracket Assemble
			
CHA013L Closure Trim Support Bracket LH (Bolster)	CHA013R Closure Trim Support Bracket RH (Bolster)	CHA009 Bolster Transom Bracket	CHA010 Bolster Hip Bracket Assembly
			
CHA012 Bolster Splay Bar Bracket	CHA006 BAG OF 25 - M4 x 13 Self Drill Philips Wafer Head	CHA007 BAG OF 25 - 4.2 x 19 Self Drill Philips Head Screw	CHA008 BAG OF 25 - 4.8 x 32 Self Drill Philips Pan Head
			
CHA002 Poly Panel Spring Clip	CHA004 Poly Support Wire Form Bolster Spacer	CHA015 Super Duty Eaves Poly Support Clip	CHA200/7 Vent Foam
			
CHA600GR/5 & CHA300/6 Top Cavity Closing Trim & Sealing Foam	CHA300/GR/4 1.25mm Plaster Stop Edge Bead - Painted	CHA165 or CHA265 Gallows Packer 165 or 265	CHA005 Single Tie Bar Cover

Should you find damaged or missing components, please always reference replacements with both a parts code (see above) and/or its position on the location plan. This will help with the speedy resolution of any issues.

GALLOWS BRACKET PRE - PREPARATION

Packer / Spacer slips over



Finished installation you need to



On an installation of roof and internal pelmet you **MUST** have this situation when you arrive on site. Structurally, it is not permissible to insert this packer / spacer when the roof is already glazed

Box Gutter - 165mm

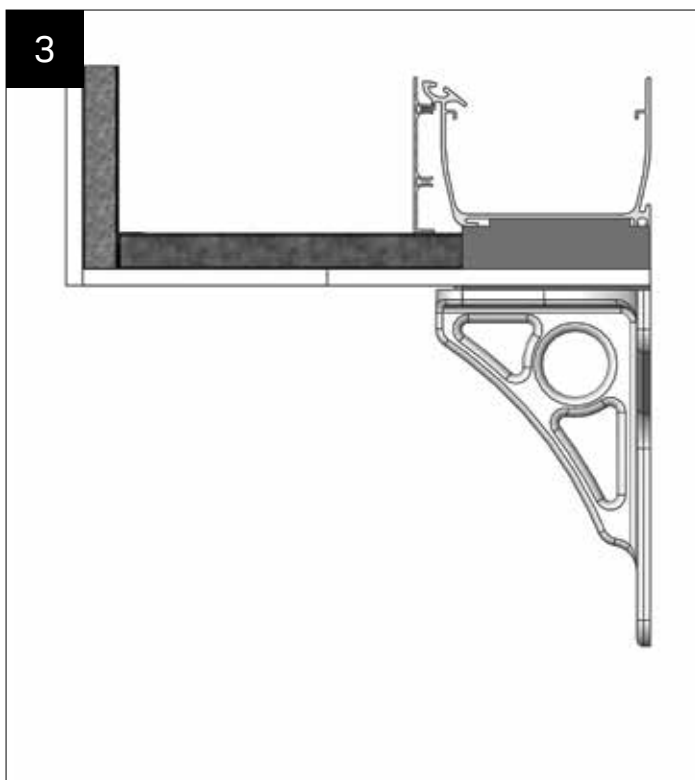

Box Gutter - 265mm

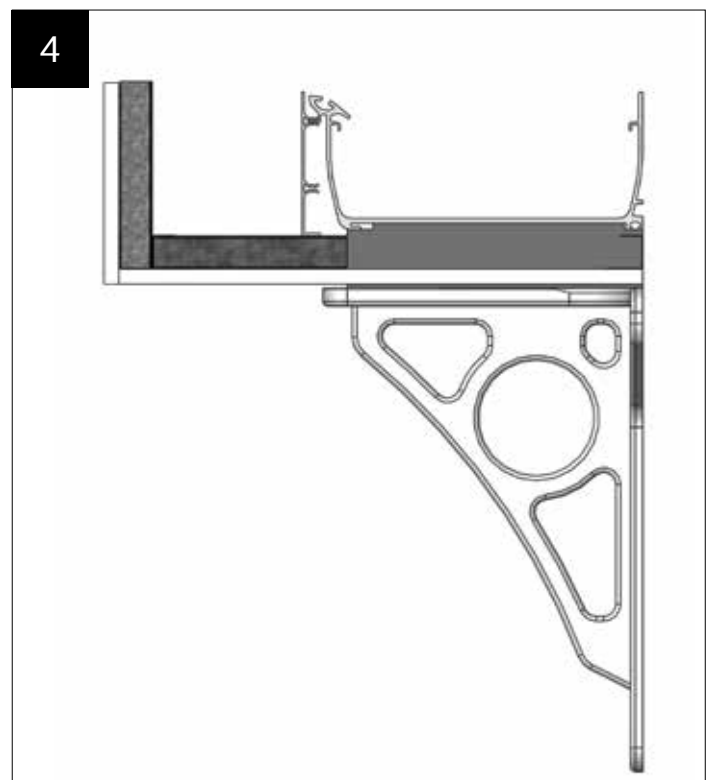

LOCATION PLAN

1

Set out & Bracket Dimensions

Job No: WU020001 (910388)	Batch/D/Bin: J0	Stock Code:
Customer: CONTEST (Concord Testing)	Manufacture: 29/09/2011	Glazing Code: ZSC
Ref:	Despatch: 30/09/2011	Ext. Finish: WHITE/
Notes:	Hub: CLUTHEROE	Int. Finish: /WHITE

Horizontal Ladders
Internal Fascia

CHS	CHA	CHA	CHA	CHA	CHA	CHA	CHA	CHA
(Bolster Bits)	009	010	011	012	013L	013R	014	015
(Bolster Bits (Per Position))	mm	mm	mm	mm	mm	mm	mm	mm

The Internal Pelmet component location plan is packed in the component box.

The location plan indicates bracket measurement / position and component positions.

EXAMPLE

Refer to separate location report

Bolster bar set outs - see page 20

INSTALLATION SEQUENCE

Additional notes if Bolsters fitted*

A FIT VENTILATION FOAM

B FIT BRACKETS

N.B NOT GEORGIAN IF BOLSTERED*

C FIT POLYCARBONATE CLOAKING SCREEN CLIPS TO FASCIA

D FIT CLOSURE TRIMS BETWEEN BRACKETS

E FIT POLYCARBONATE CLOAKING SCREEN

N.B FIT POLYCARBONATE CLOAKING SCREEN SUPPORT CLIP TO SCREEN IF BOLSTERED*

F FIT HORIZONTAL LADDER & TEMP SUPPORT

N.B FIT CORNER LADDER INFILLS IF BOLSTERED*

G FIT VERTICAL LADDERS

H FIT PLASTERSTOP EDGE BEAD

INSTALLATION - VENTILATION



2

3

FITTERS TIPS - Some consider it good practice to silicone seal round ends of support trim

When the roof and internal pelmet are ordered together, this ventilated glazing support trim arrives with breather foam already inserted into the cavity to prevent insect ingress.

If the internal pelmet is being installed into an existing older roof, it is important that the steps to the right and below are followed.

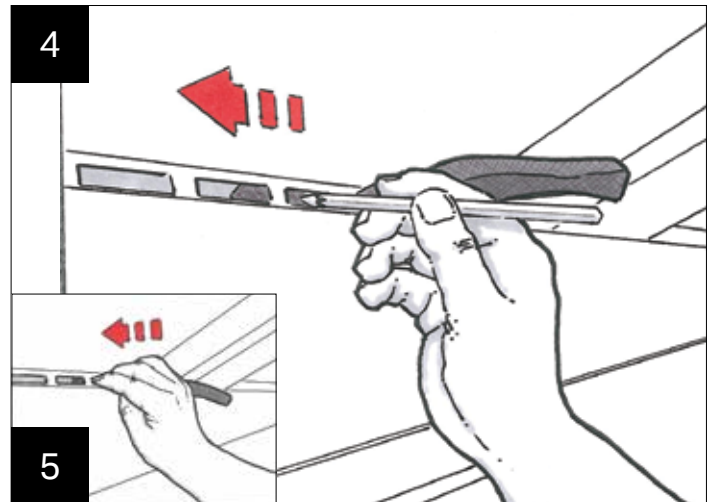

If the existing roof already has Eavesflow ventilators fitted, unclip and dispose of the ventilators and then introduce the foam strip using a pencil and thread along until all the slots have the foam behind.

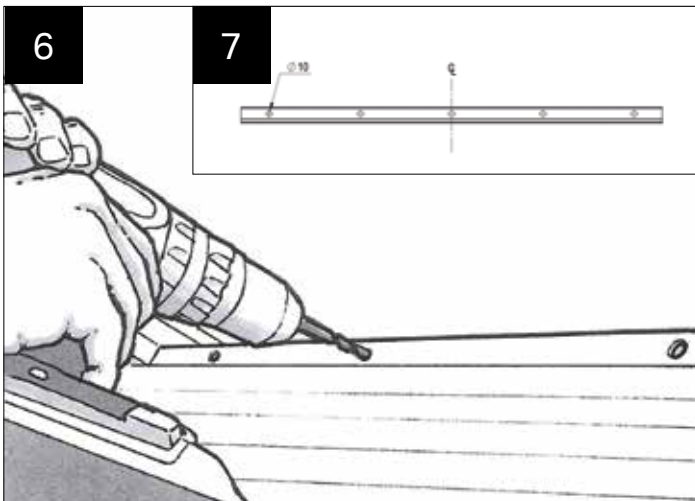

If the existing roof doesn't have Eavesflow fitted, then take a 10mm drill and drill through the glazing support trim from inside to outside to create 5 holes per 'bay' - ensure this is done over the length of 250mm, centred in the middle of the glazing panel.

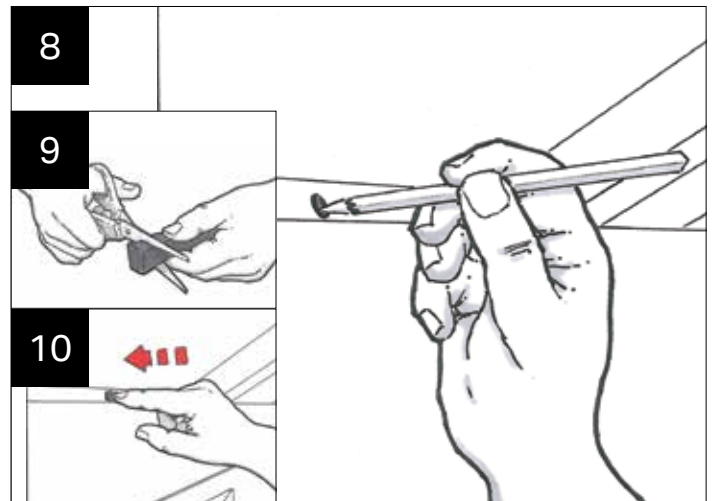

Now, cut the foam strip into 25mm pieces and insert into each hole, ensuring it sits comfortably and unobtrusively into each hole.

INSTALLATION - BRACKETS

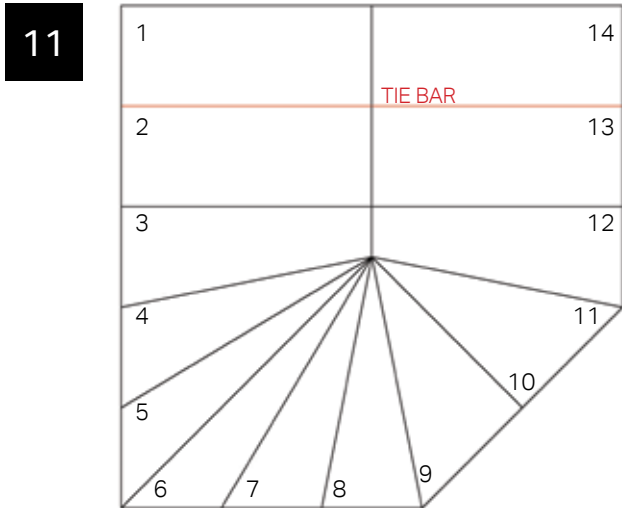

12

ROOF POSITION	STANDARD BAR BRACKETS POSITION (mm)			
	CHA001	CHA003	CHA090	CHA011
1, 2, 3, 12, 13, 14	200			
4, 5				389
6			382L/389R	
7, 8				382
10	384	384L/389R		
11		384L/384R		
	TRANS	ADJ HIP	GEORGIAN HIP	SPLAY

EXAMPLE
Refer to separate location report

IMPORTANT NOTE: Left (L) and right (R) dimensions are viewed internally.

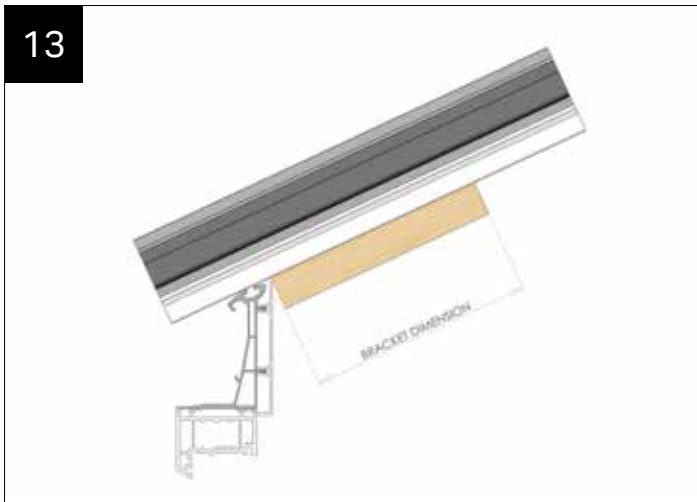

Measurements are ALWAYS from the top edge of the PFTB fascia board.

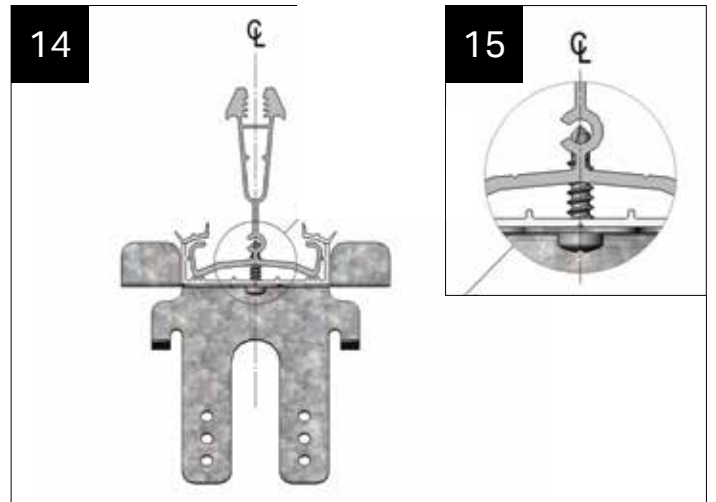

NOTE: Bracket fixing screws must be fit central of glazing bar, mark up the centre line of the bar on to the undercladding if it is not clear by sight.

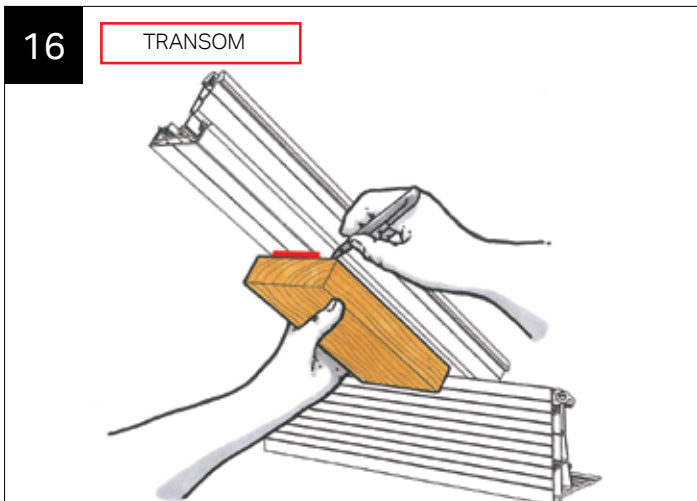

Using the location plan provided – see example above – find the dimension for setting out clip positions on the transom bars. Measure up the bar from top edge of fascia board, and mark it (see 13 above). If your roof features many transom bars, it may be simpler to cut a piece of timber to length and use as a template.

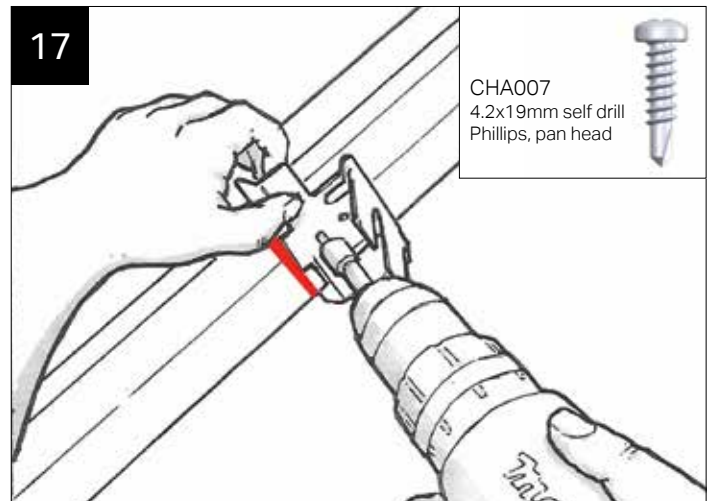

Take the transom bracket (CHA001) and attach using two 4.2 x 19mm self drill Phillips pan head screws supplied- the back edge of the bracket should butt up to the pencil line.

INSTALLATION - BRACKETS

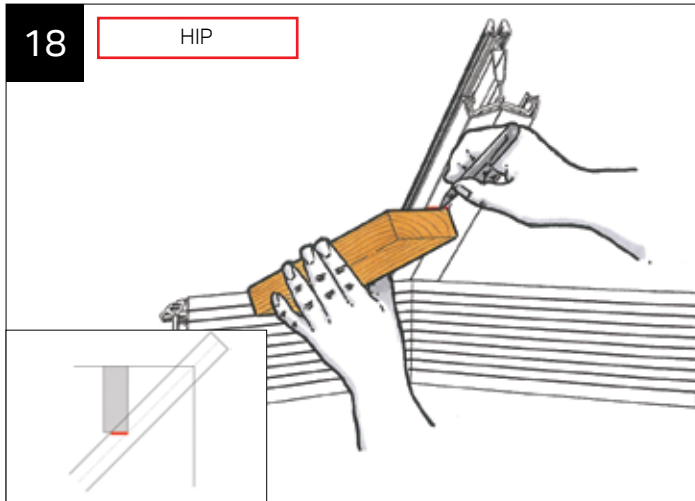

Similar to step 16, seek the set out dimension from the location plan (12) for the Georgian or Victorian bar. Mark with a pencil line. Please note the dimension will be different from the transom bar. This graphic shows the left hand dimension being marked. Timber template to be held square to fascia board.

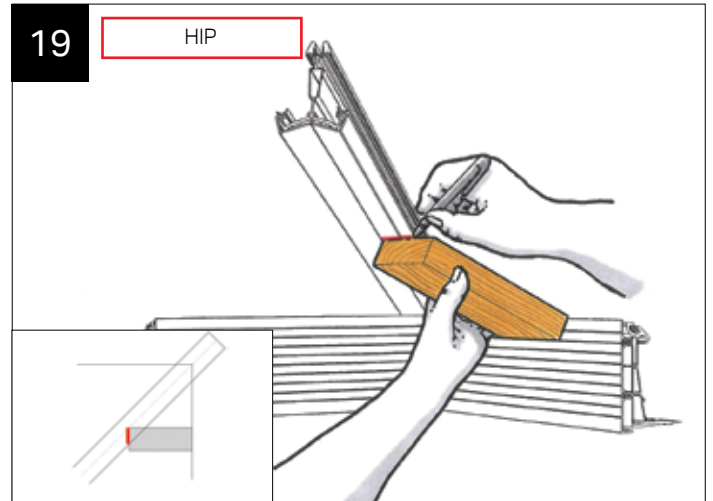

From the location plan, now mark the right hand fixing position

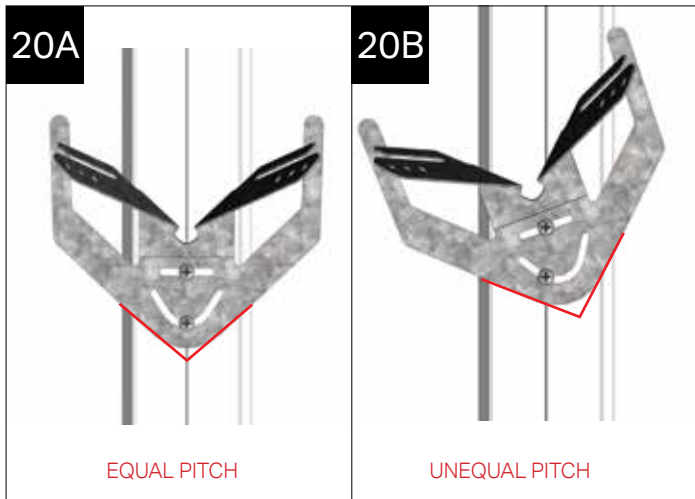

Now offer up the Georgian hip bracket (CHA090) – where the roof is equal pitch across the hip, the bracket should sit as (a). On unequal pitches, the bracket may be skewed as in (b)

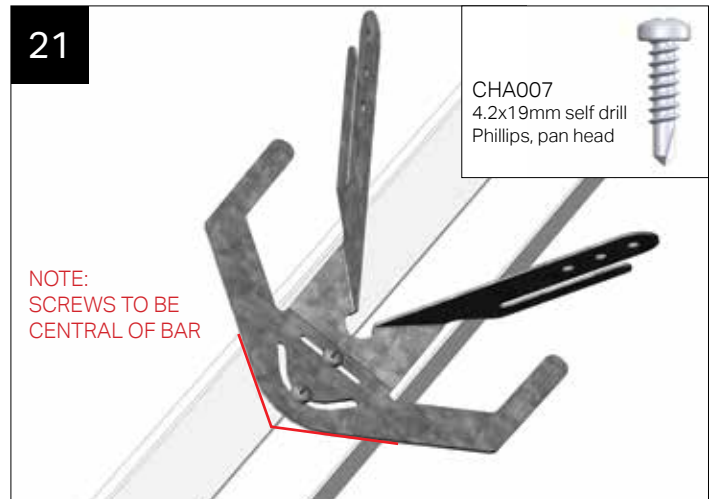

Now attach using one of the two 4.2 x 19mm self drill Phillips pan head screws supplied – one screw curved top slot - do not 'nip up' at this stage, but allow bracket to pivot.

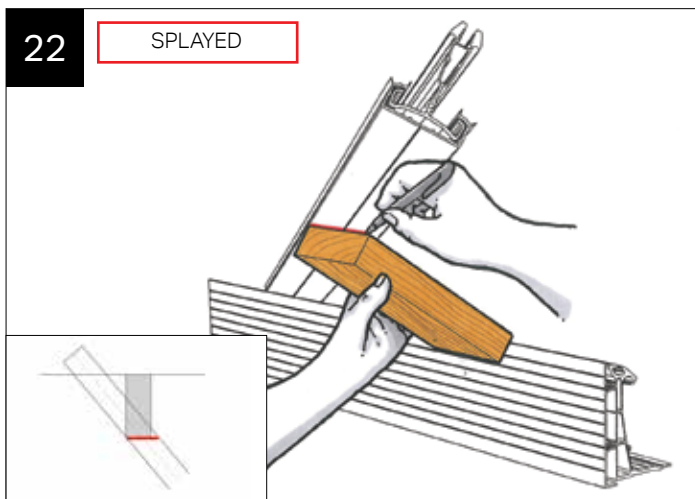

On a splayed bar – 7 and 8 on the sample location plan – measure and then strike a line across the face of the splayed bar's undercladding. Timber template to be held square to fascia board.

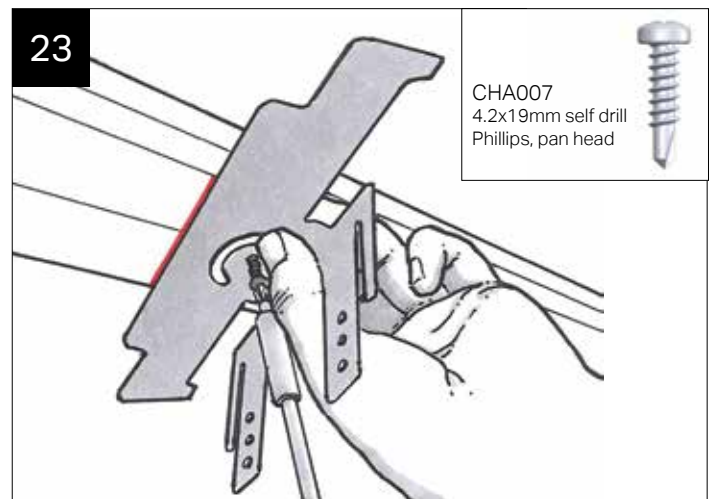

Now attach bracket CHA011 using one 4 x 19mm self drill Phillips pan head screw – ensure screw in curved slot is in centre line of bar.

INSTALLATION - BRACKETS / CLOAKING PANEL CLIPS

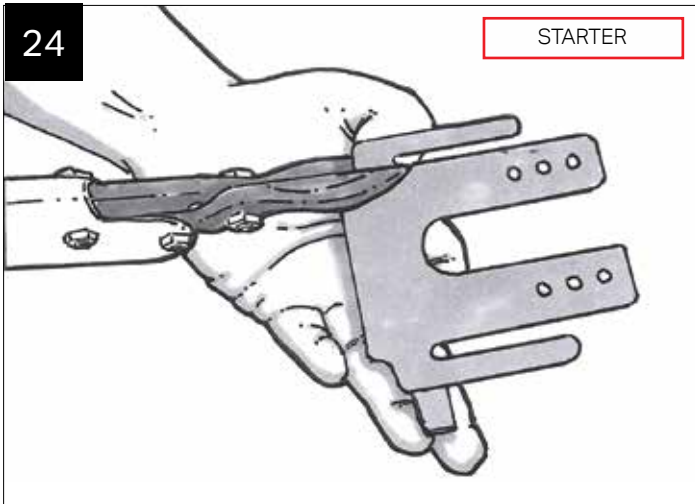

On the starter bar, take a CHA001 Transom bracket and snip off the long leg tab – if the wall is already plastered, further trimming maybe required.

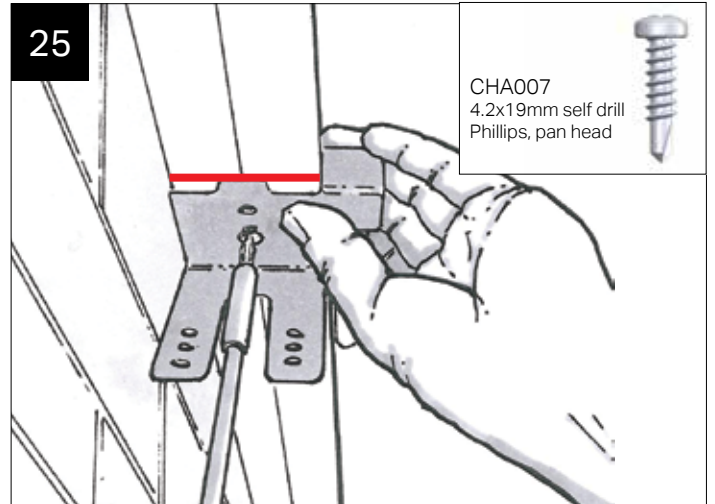

Measure, mark and fit the trimmed down starter bracket using two 4.2 x 19mm self drill Phillips pan head screw.

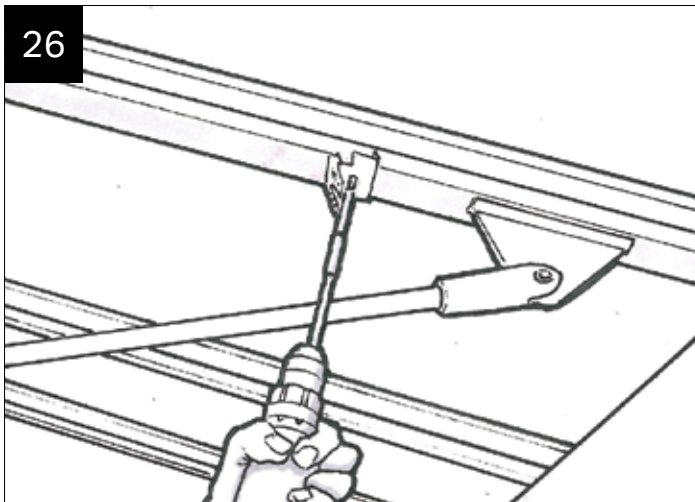

When there is a transom bracket on the same glazing bar as a tie bar, it is suggested that a long driver bit is used to facilitate easy fitment.

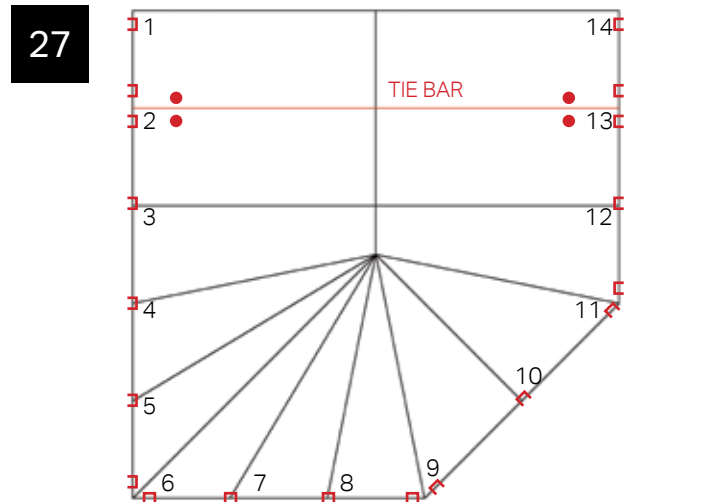

Symbol '□' shows if one support clip is needed central to the bar or one each adjacent to the bar - see 28 and 29 below. Additional CHA004 brackets '●' at tie bar position - see steps 41 & 42.

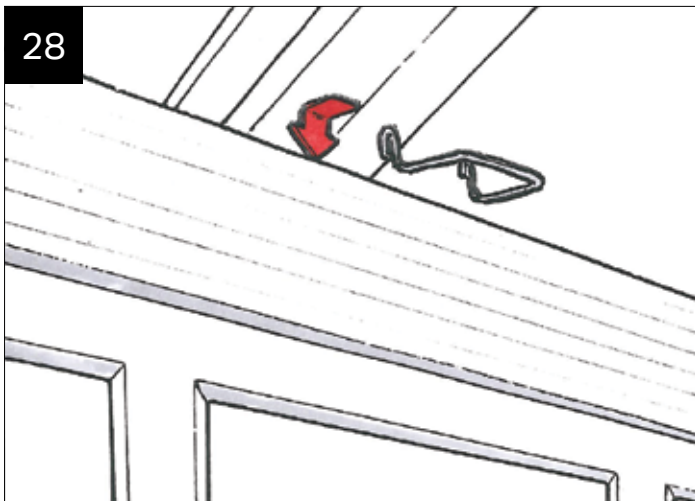

Over the planked fascia board at the eaves, at each transom (but not tie bar locations) and splayed bar position, hook over the cloaking panel support clips CHA002.

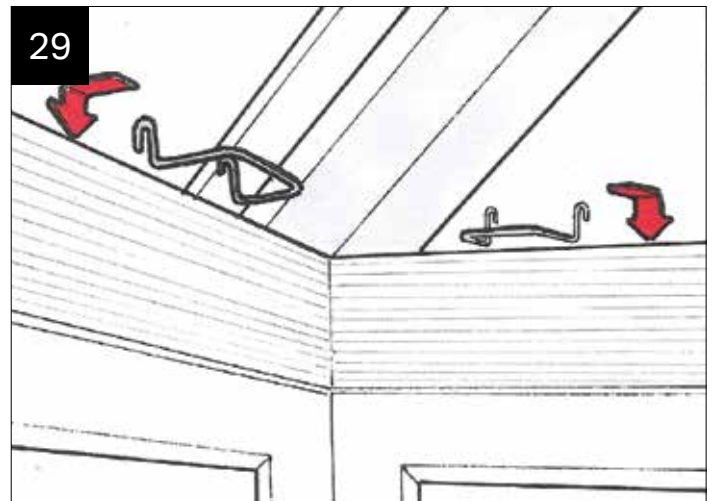

On starter bars, hip bars and transoms with tie bar brackets, a cloaking panel support clip is placed each side of the bar.

INSTALLATION - CLOAKING PANEL CLIPS

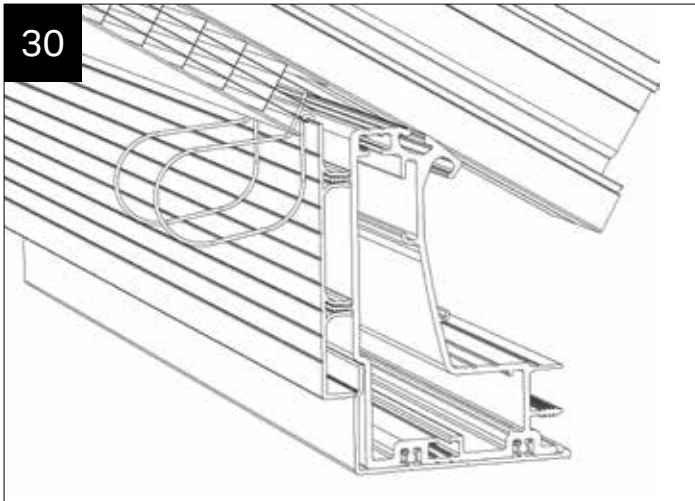

IMPORTANT NOTE: If Super Duty eaves beam is used, then these are the cloaking panel clips that are supplied.

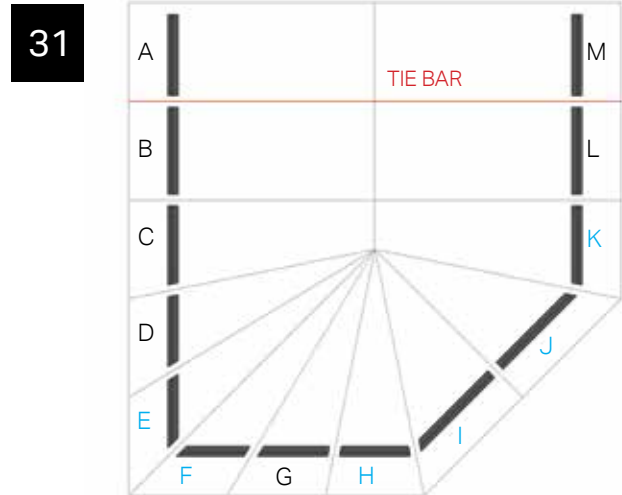

Select the cloaking panel (polycarbonate) support trim for the positions indicated in Black (A, B, C, D, G, L, M).

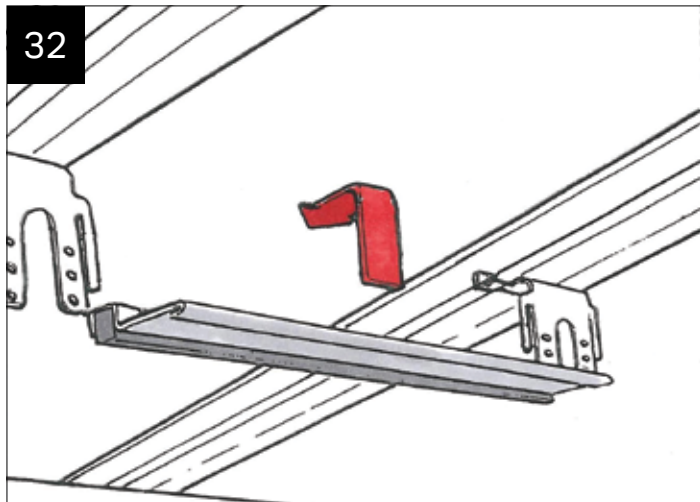

Offer into position the cloaking panel (polycarbonate) support trim – this is lifted up and over the two tabs – one per side of either the transom or Georgian brackets.

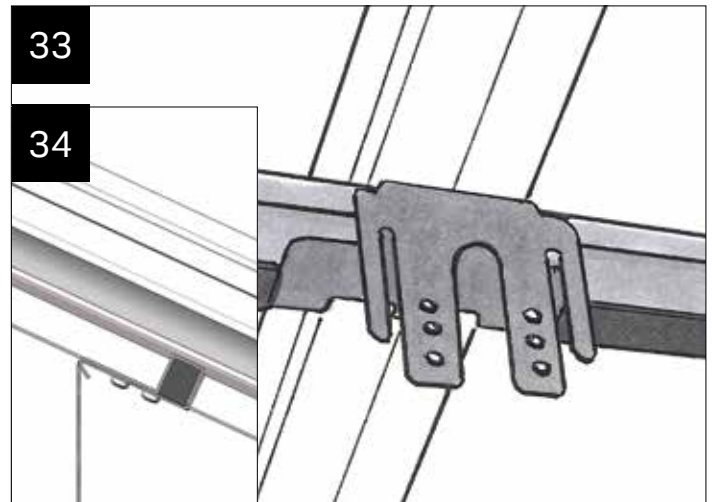

This is what you should see from the underside and the side view.

Now select the cloaking panel (polycarbonate) support trim for the remainder of the positions indicated in 31 in blue (E, F, H, I, J, K).

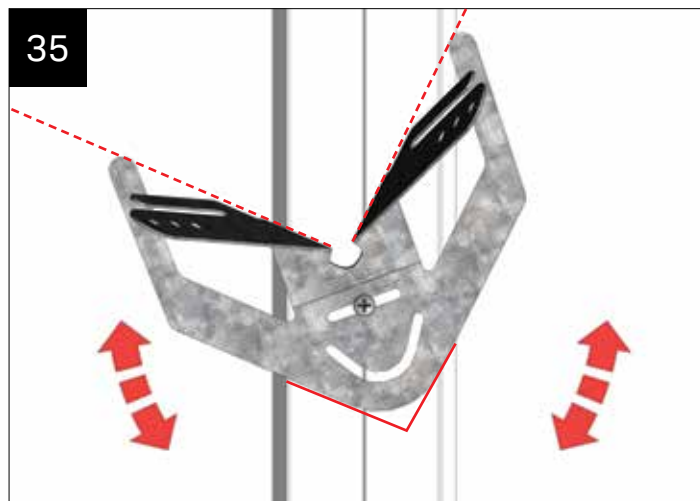

The hip bar bracket is free to rotate at the moment.

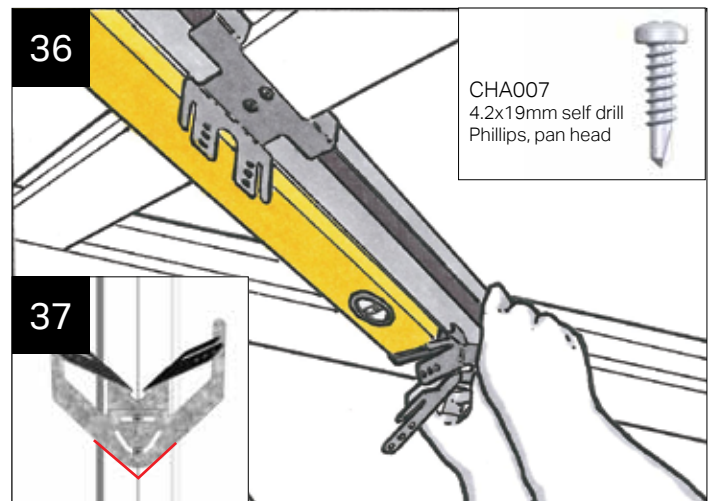

Using a long level butted up to the brackets on the transom bars adjacent, strike a line through to locate the final position. Tighten up the one previously fixed screw and add one more 4.2 x 19mm self drill Phillips pan head screw.

INSTALLATION - POLYCARBONATE CLOAKING PANELS

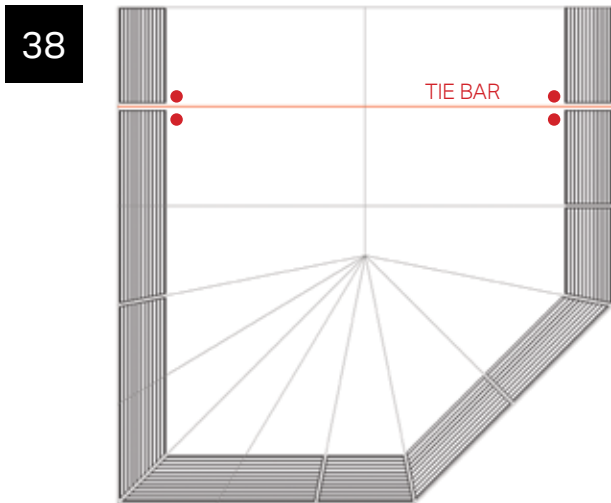

Now it is time to install the polycarbonate cloaking screen panels. See steps 41 - 42.

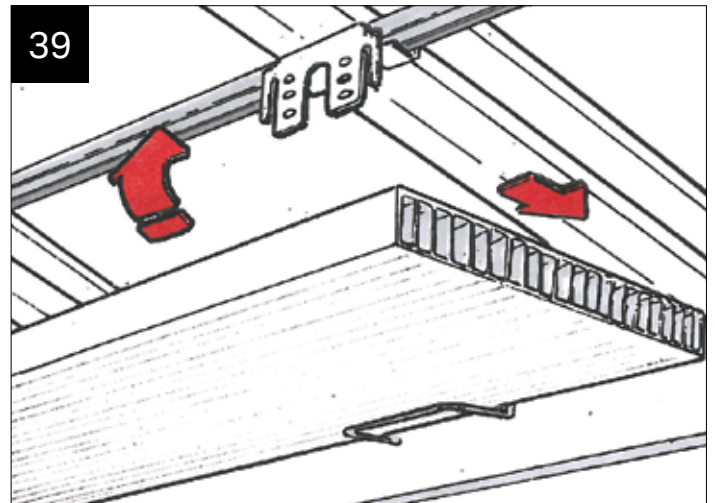

Referring to the location plan, take the appropriate piece of polycarbonate cloaking panel which lays parallel to the eaves. Next, 'sit' it into each of the support clips that are hooked over the fascia. Then push the polycarbonate up into the roof.

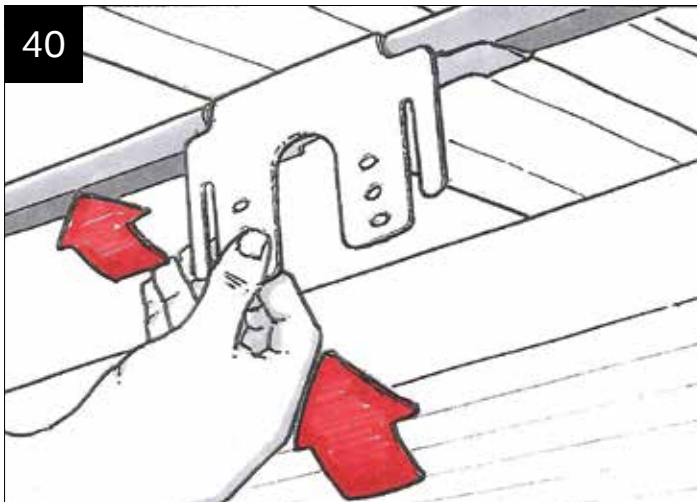

As the polycarbonate is swung into position, the transom brackets may need to be bent slightly backwards to allow the polycarbonate to clear them.

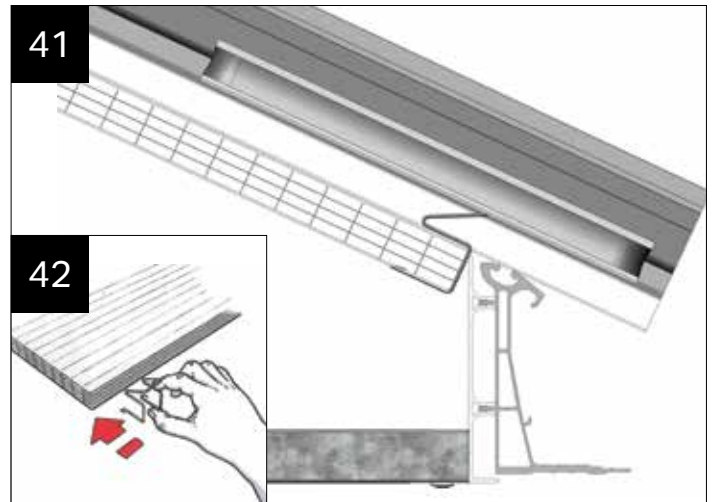

On glazing bars featuring tie bar brackets or those with bolsters, use CHA004 attached to the polycarbonate (acts as a spacer). See step 38 and '●' symbol shows where they are fitted.

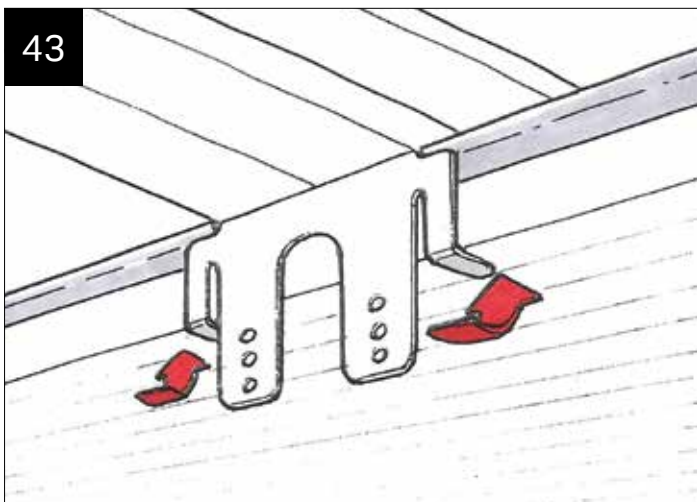

Next bend back the long legged tabs to hold the polycarbonate cloaking trim in its final position.

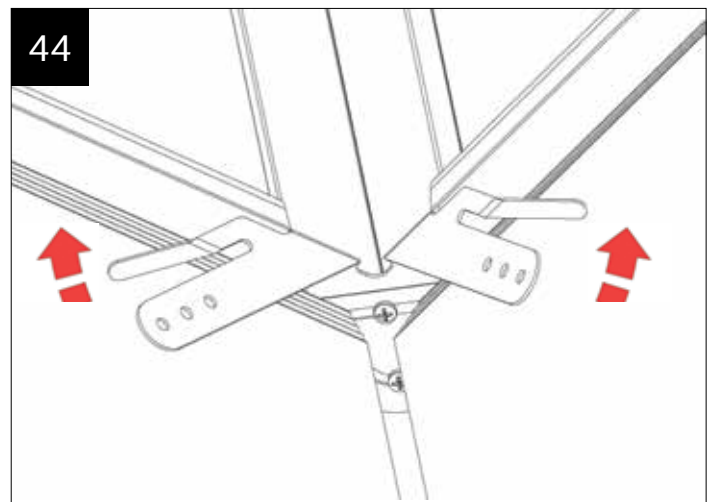

Undertake the same task on the Georgian brackets – ensure the polycarbonate cloaking panel is secured each side of the hip.

INSTALLATION - HORIZONTAL LADDERS

45

Set out & Bracket Dimensions

Job No:	WAG0001 (910388)	Batch/Rev:	0	Stock Code:	
Customer:	COMTEST (Conrad Testing)	Manufacture:	29/09/2011	Glazing Code:	ZIC
Ref:		Despatch:	30/09/2011	Ext. Finish:	WHITE
Name:		Prod:	CLUTHERICE	Int. Finish:	WHITE

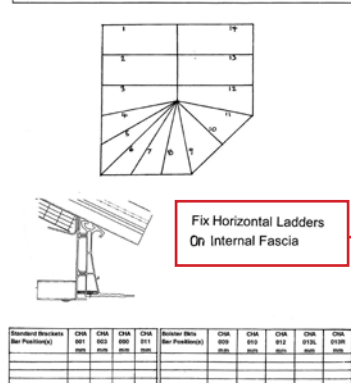

Fix Horizontal Ladders
On Internal Fascia

Standard Brackets (See Positioning)	CHA 001	CHA 002	CHA 003	CHA 011	Receiver Brackets (See Positioning)	CHA 004	CHA 010	CHA 012	CHA 013	CHA 014	CHA 015
	mm	mm	mm	mm		mm	mm	mm	mm	mm	mm

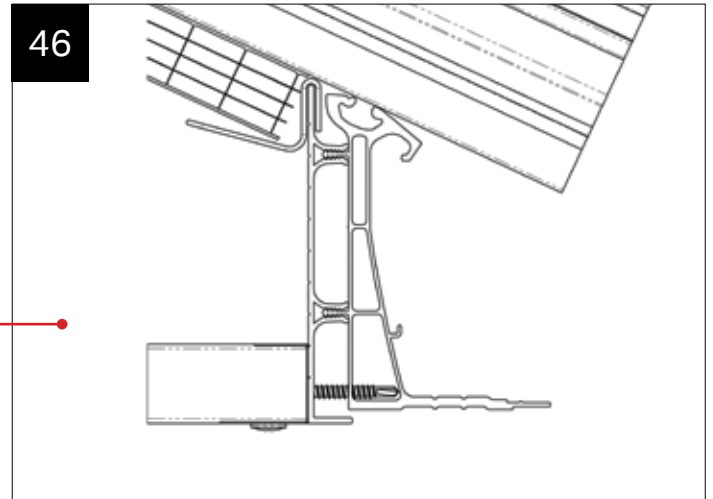

IMPORTANT NOTE: Now check on the 2 page location plan whether the horizontal frame is for 'on fascia' fixing (see 46) or 'below fascia' fixing (see 47).

ON FASCIA

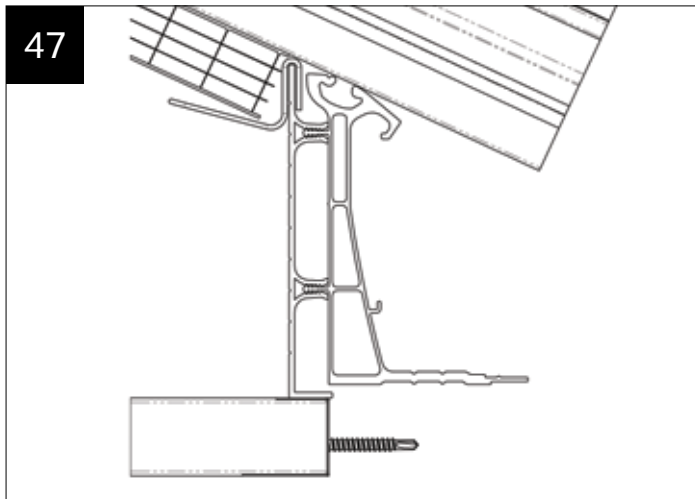

BELOW FASCIA

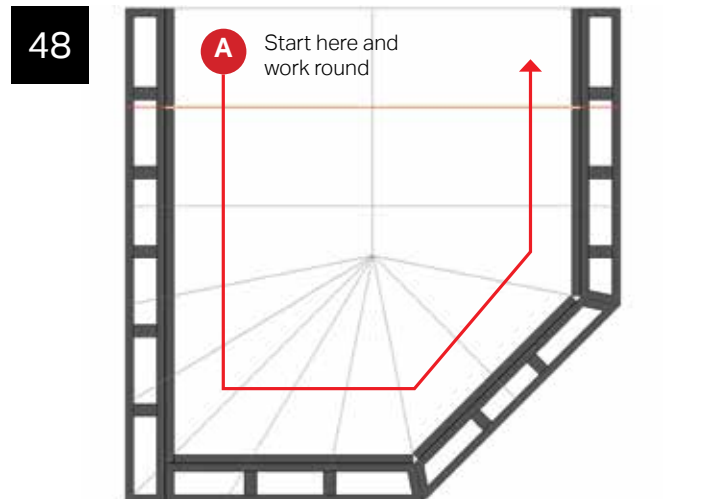

Refer to the location plan and always start from position A.

- All ladders are labelled with the same number as the eaves beam they are attached to (from the location plan),
- Then they have a V or a H depending whether they are a horizontal or vertical ladder,
- If the ladder is split into pieces due to the ladder going over length, or being split by bolsters, tie-bars etc then they additionally labelled with an "a", "b", "c", "d",...

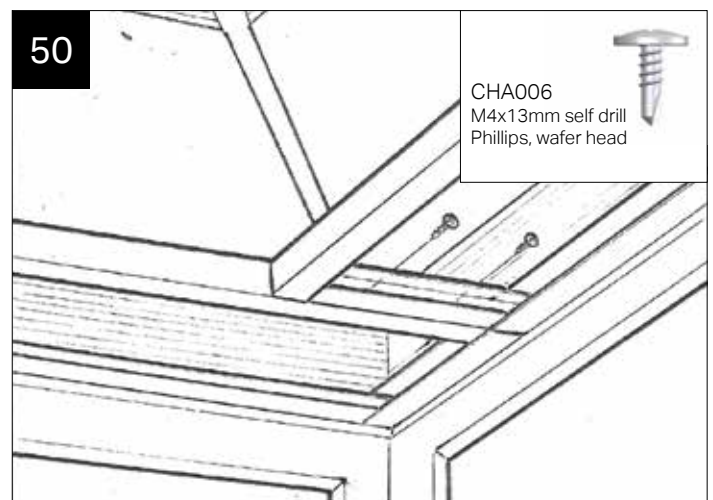
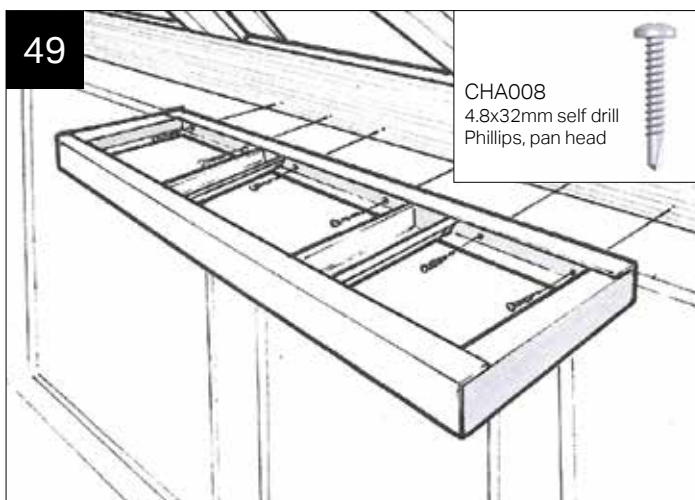

Offer up the first horizontal ladder- An adjustable support prop will help you here. Use two fixings 4.8 x 32mm CHA008 at 250mm centres into pre punched holes to attach the ladder.

To attach two horizontal ladders at the corner use two fixings M4 x 13mm per butt joint.

INSTALLATION - VERTICAL LADDERS

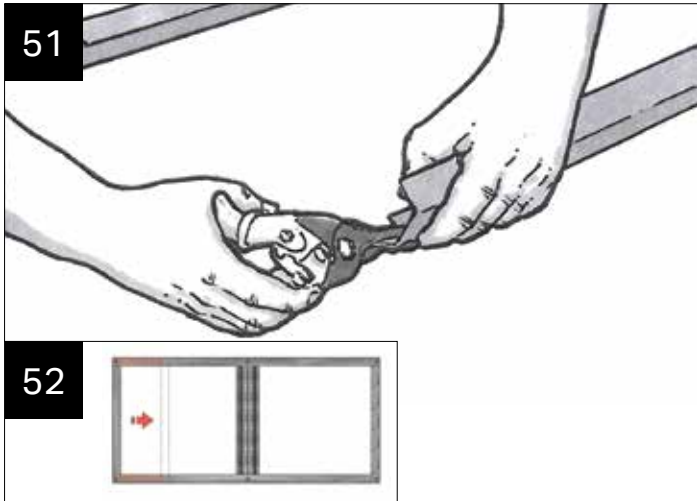

If it is necessary alter length of frames, simply remove end rail, trim with tin snips and reconnect.

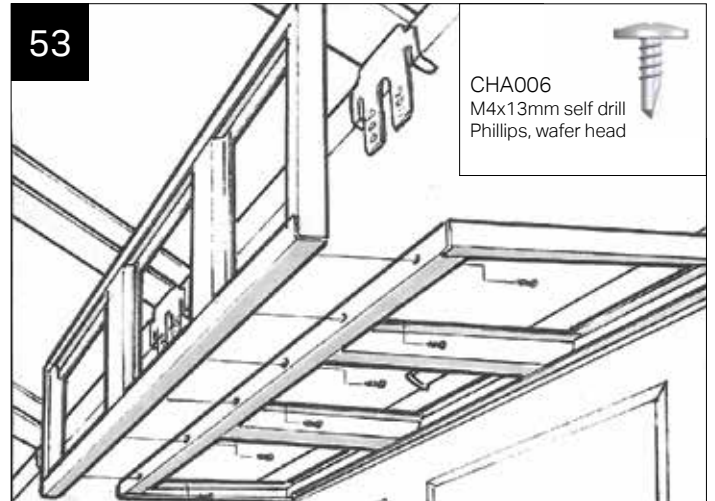

Using the location plan, choose the matching vertical ladder and offer it into position – hold firmly whilst attaching to the matching horizontal ladder using M4 x 13mm fixings, at 250mm centres into pre punched holes. Ensure the vertical ladder is behind the brackets

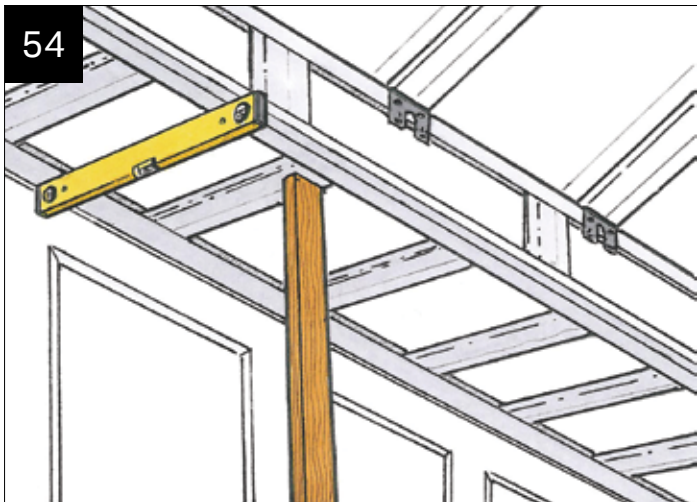

Undertake a final check that all is plumb, level and true

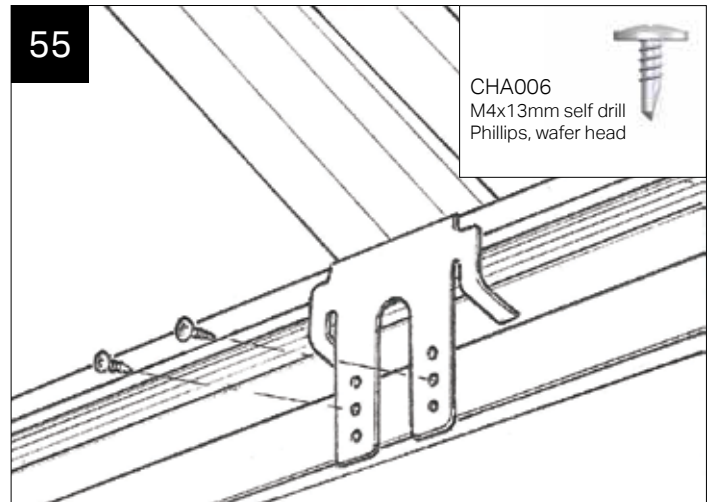

For each transom bracket use two M4 x 13mm fixings – the layout of the ladders should help you chose which of the three fixing positions to choose from.

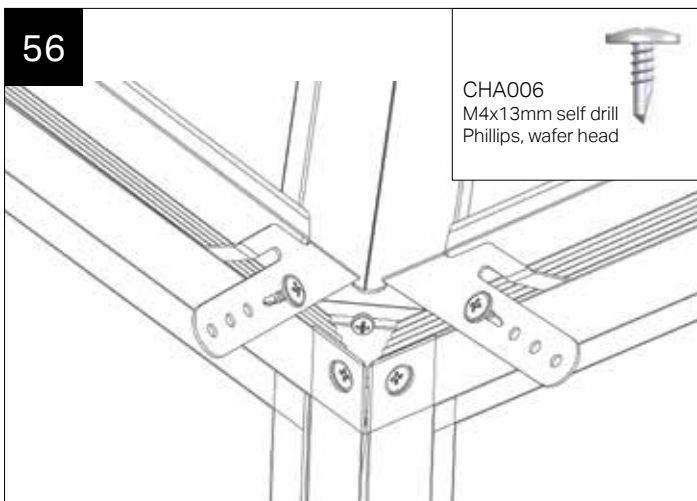

On the Georgian bar, use one fixing per side to fasten the bracket to the vertical ladder – use M4 x 13mm fixings.

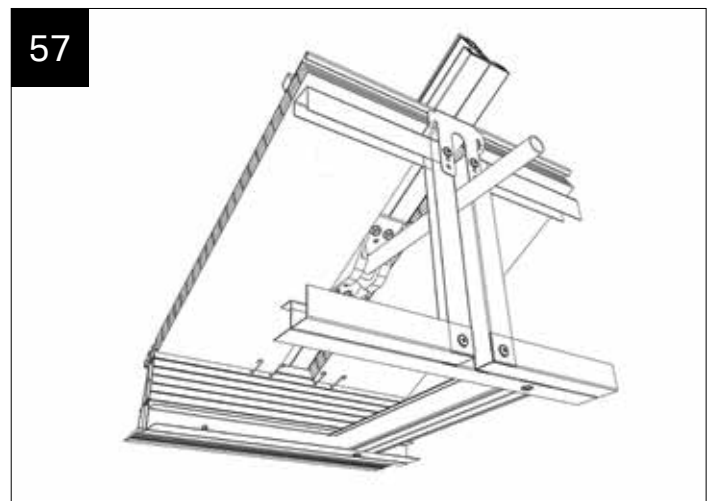

This is the arrangement around tie bars

INSTALLATION - OTHERS

58

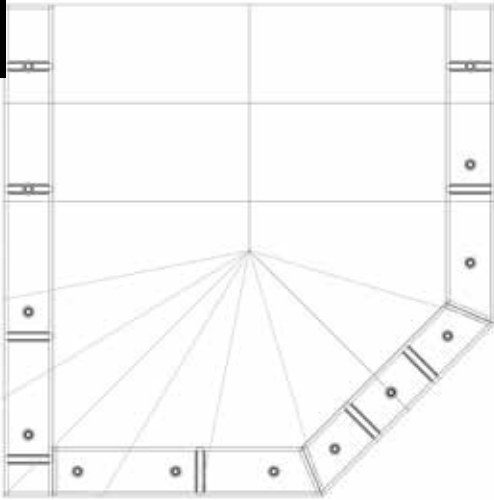

IMPORTANT NOTE: Before applying 12.5mm foil backed plasterboard to ladder framework check lighting positions and adjust horizontal ladders to suit see step 59

59

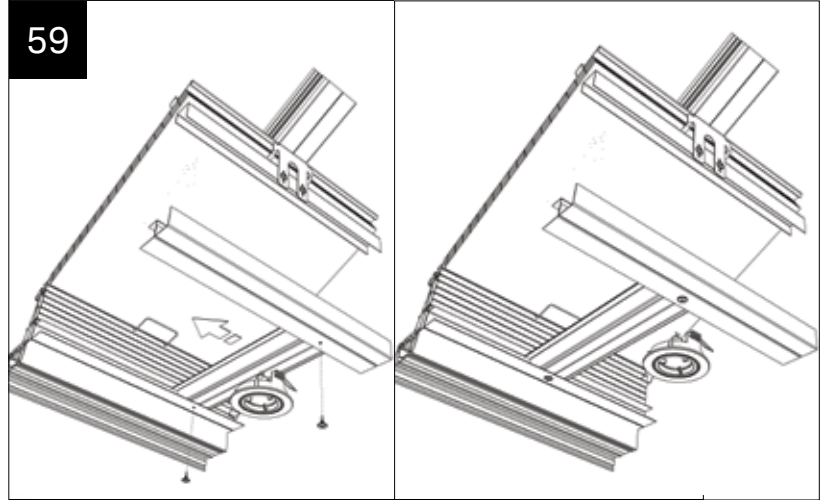

If a spotlight clashes with a cross rail, simply unscrew the cross rail and relocate as close as possible to the original location. Spot light no longer clashes as horizontal ladder is re-configured on site

PLASTERBOARDING & PLASTERING

Guidance is based on advice provided by the SITE BOOK available from www.british-gypsum.com or call 0844 800 1991 bgtechnical.enquiries@bpb.com

This guidance based on the use of Thistle Finishing Plaster and 12.5mm Gyproc Wallboard Duplex T/E which has an additional metalised polyester film to act as a vapour control membrane.

- Based on a 2mm skim finish. Temperature must be maintained above 5deg C until plaster is dry.
- Plaster skimming should always commence as soon as possible after the boards are fixed.
- Use thin wall beads attached with 'dabs' of plaster – to provide additional support during drying, attach with non-rusting nails, screws or staples
- Reinforce flat joints with Thistle ProTape 50 or FT100 – these are made from glass fibre and are self adhesive and fitted before plastering.
- Any gaps bigger than 3mm must be pre-filled and reinforced using Gyproc Joint Tape which is embedded in the first coat over each joint, where sufficient plaster is left under the tape to ensure good adhesion and then a second plaster application used. This method is better resistance to cracking than glass fibre tapes.
- Apply Thistle Finishing Plaster with firm pressure, build out to 2mm thickness in two applications and then trowel to a smooth finish.

1

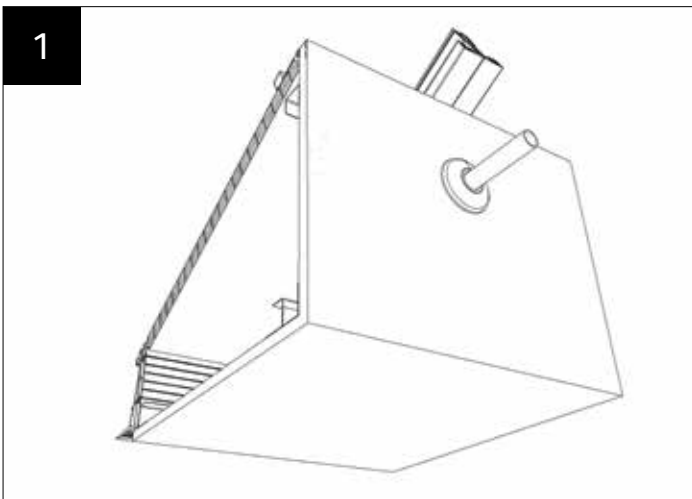

Once 12.5mm plasterboard is fitted, the tie bar rose (CHA005) flexes over the PVC conduit and should be spot bonded into position

2

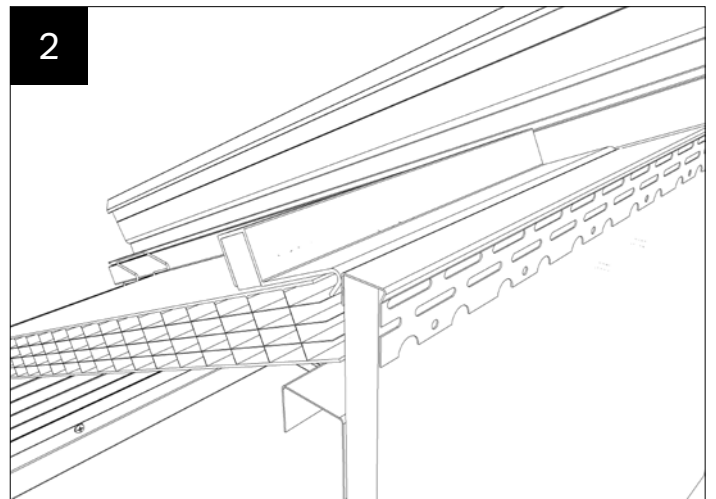

Ultraframe supplies a plasterers stop bead (CHA300) for the top edge adjacent to the glazing – ensure it is attached as shown. Be careful when handling/cutting this item not to damage the paint surface.

INSTALLATION - BOLSTER BARS

1

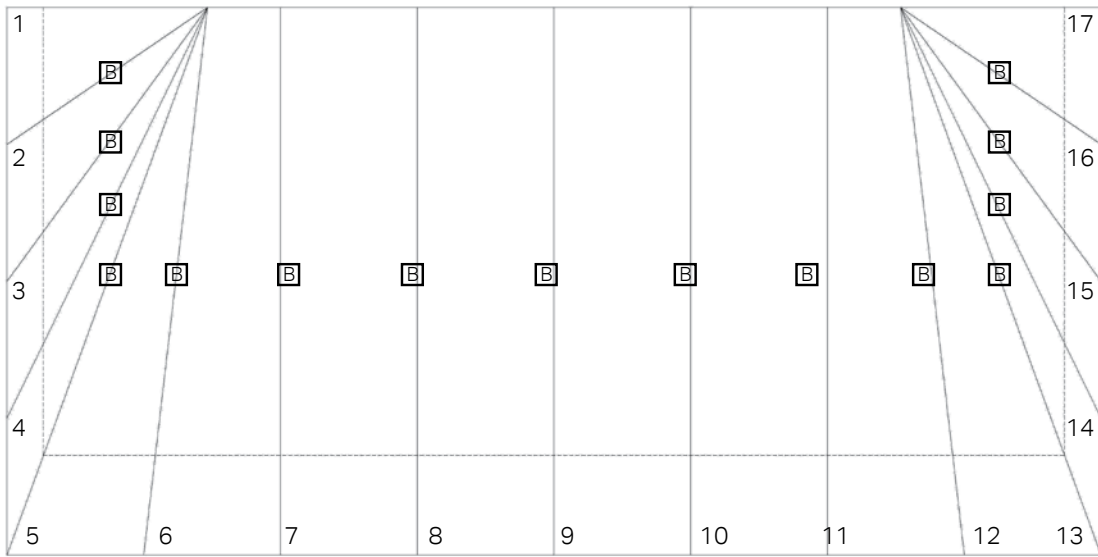

USE THE LOCATION PLAN TO FIND THE BOLSTER BAR LOCATION DETAILS

2

ROOF POSITION	STANDARD BAR BRACKETS POSITION (mm)				BOLSTER BAR BRACKETS POSITION (mm)				
	CHA001	CHA003	CHA090	CHA011	CHA009	CHA010	CHA012	CHA013L	CHA013R
1, 17	304								
2							228	-1	58
3							219	-4	115
4							216	0	178
5						Fit to suit		702	780
6							699	34	-5
7, 8, 9, 10, 11					-26			728	728
12							699	-5	34
13						Fit to suit		780	702
14							216	178	0
15							219	115	-4
16							228	58	-1
	TRANS	ADJ HIP	CRUCIAN HIP	SPLAY	TRANS BOTTOM	HIP	SPLAY BOTTOM	LEFT SIDE	RIGHT SIDE

3

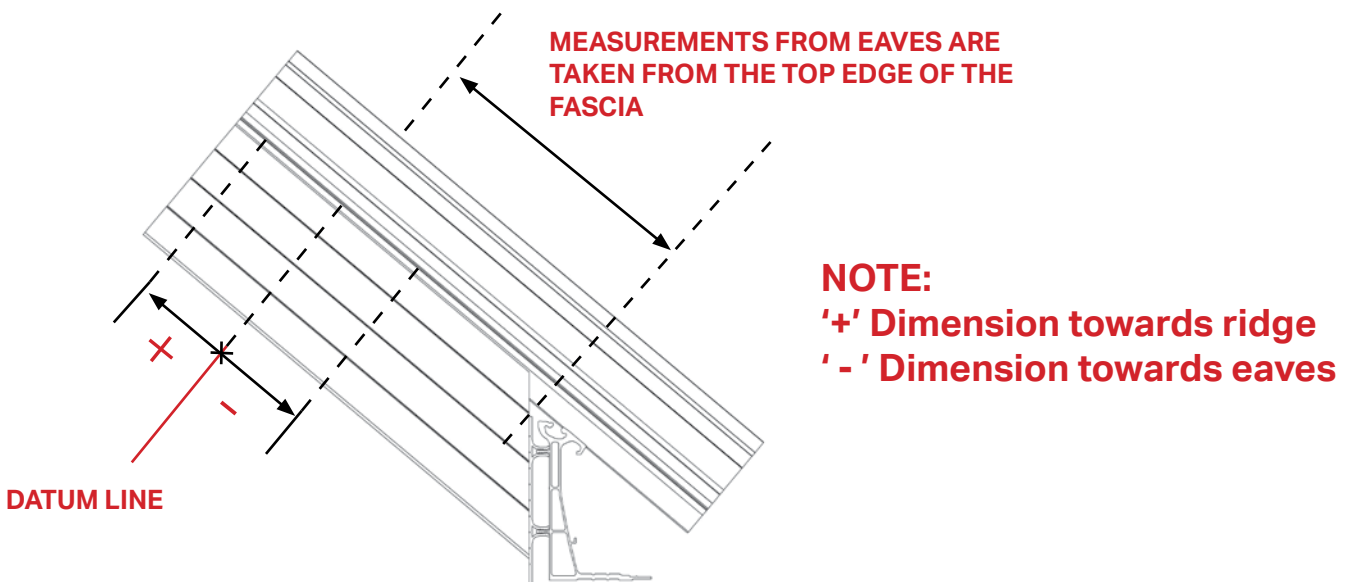

INSTALLATION - BOLSTER BARS - TRANSOMS

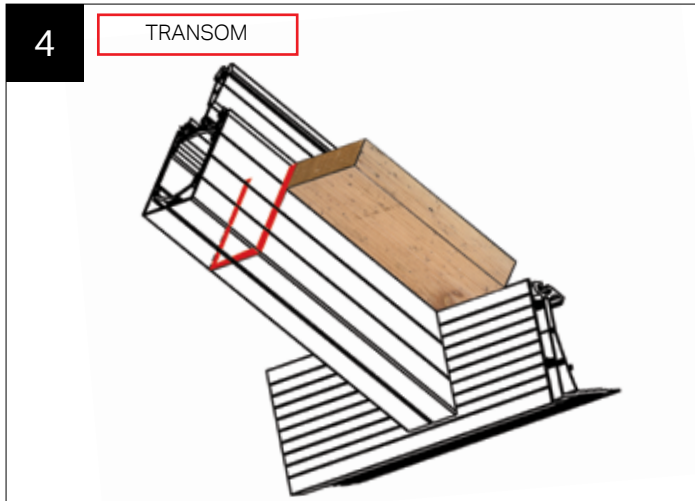

Using the location plan provided – see example in fig 1 – find the dimension for setting out bracket positions on the transom bars. Measure up the bar from the eaves beam, and mark the bolster cladding on all three sides. If your roof features many transom bars, it may be simpler to cut a piece of timber to length, to use as a template and mark using that.

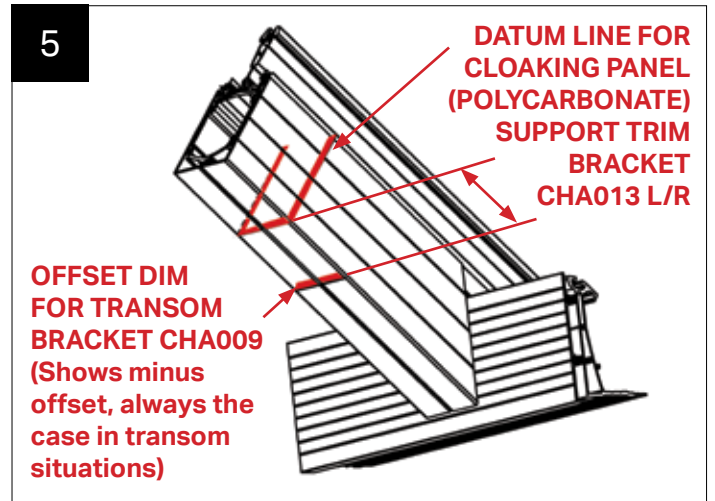

Using the bolster set out data on the location plan, mark each of the transom bars, for the bottom bracket using the offset dimension, always measuring down towards the eaves in transom situations.

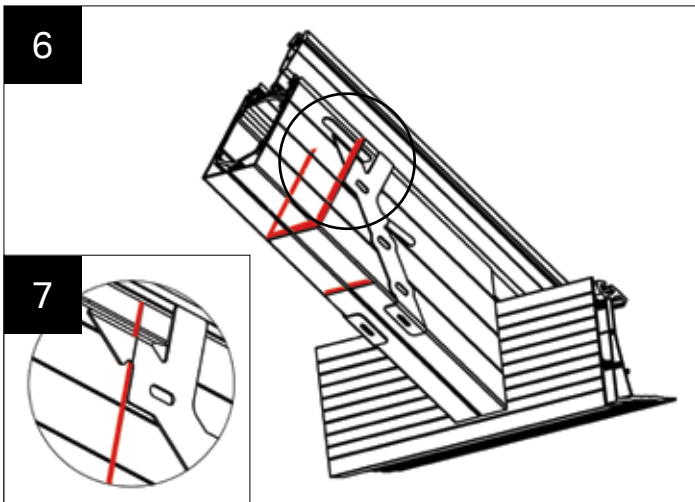

Take the bracket CHA013 L or R (fig 7) and line up with datum line (see inset diagram)

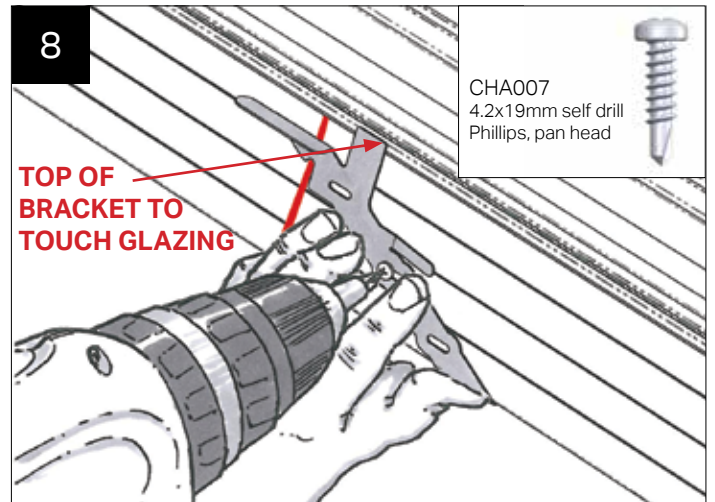

Now attach the bracket with a minimum of two CHA007 4.2 x 19mm self drill panhead Phillips screws. Repeat the process for the L (left) side bracket.

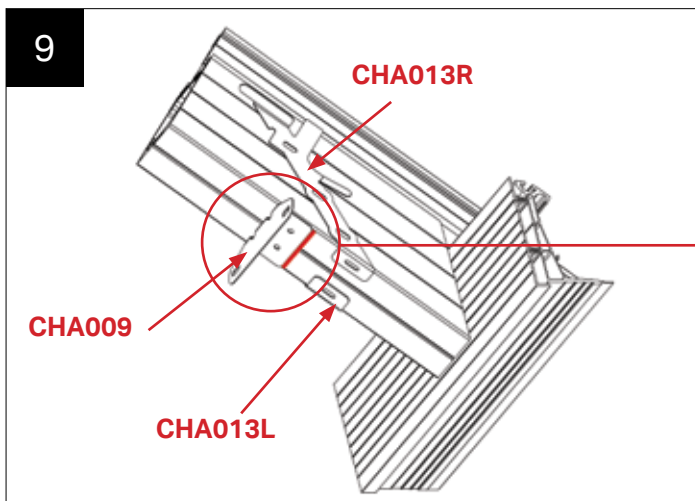

Then take the CHA009 transom bracket and line it through with the pre-marked minus offset dimension – see illustration alongside. Fasten with two CHA008 4.8 x 32mm self drill panhead Phillips screws.

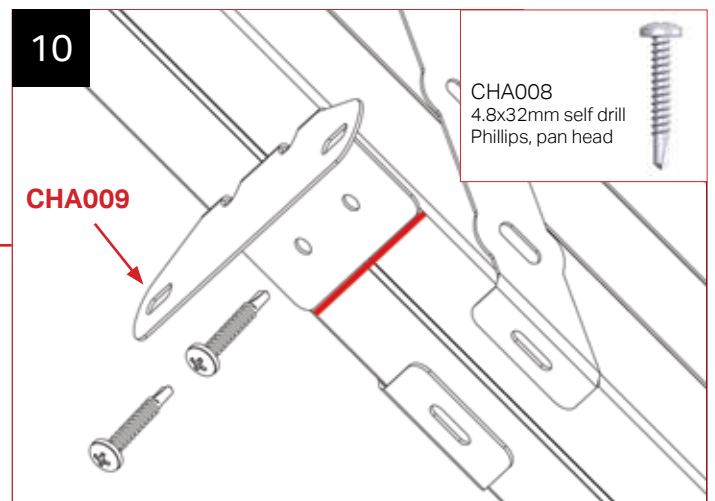

INSTALLATION - BOLSTER BARS - HIPS

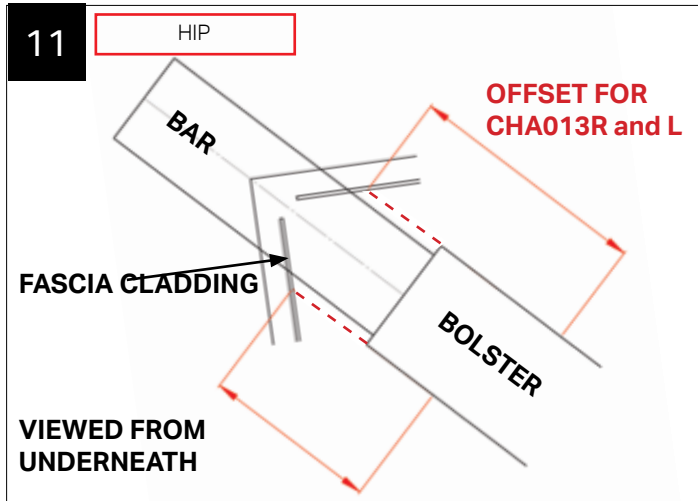

Looking from underneath the bolstered Georgian hip bar, strike a line down the side of the bolster cladding and put a datum line on top of the fascia.

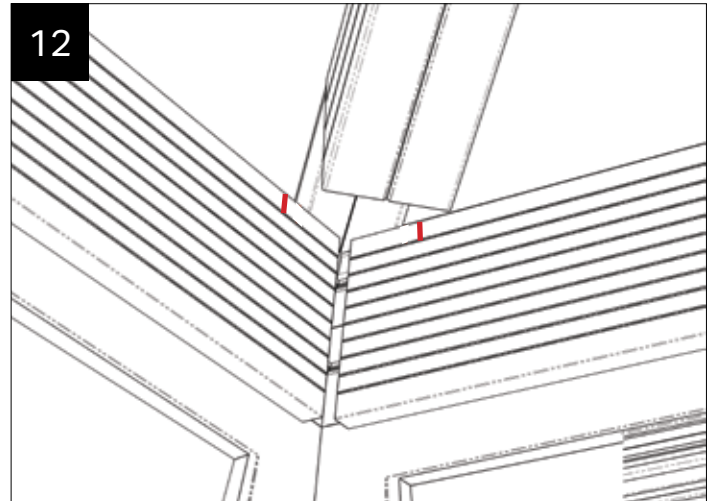

This is how it should look when you have marked each side of the eaves fascia with a datum point to measure from.

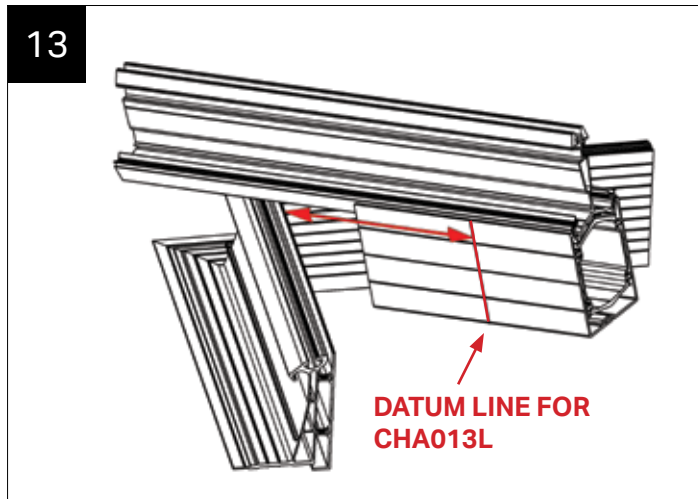

Now referring to the location plan, check the dimensions for left and right. Measure up the bar from the datum mark and mark both the side and face of the bolster cladding from the datum mark. Complete the task on left and right sides – the dimension may be different for each side.

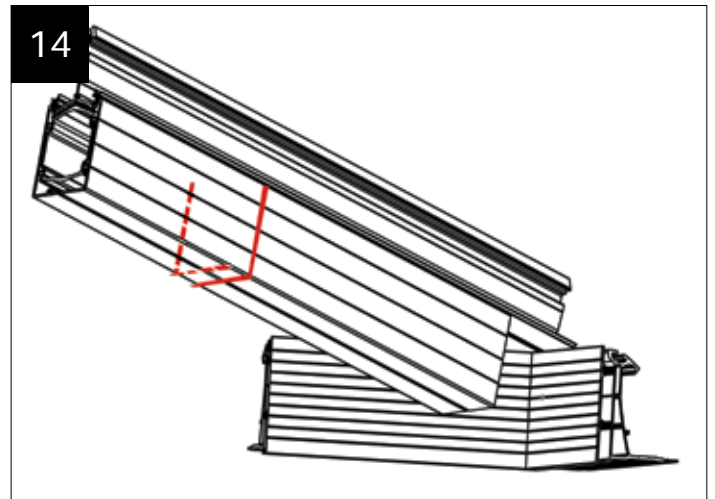

This is how it should look once you have measured and marked the hip bolster cladding.

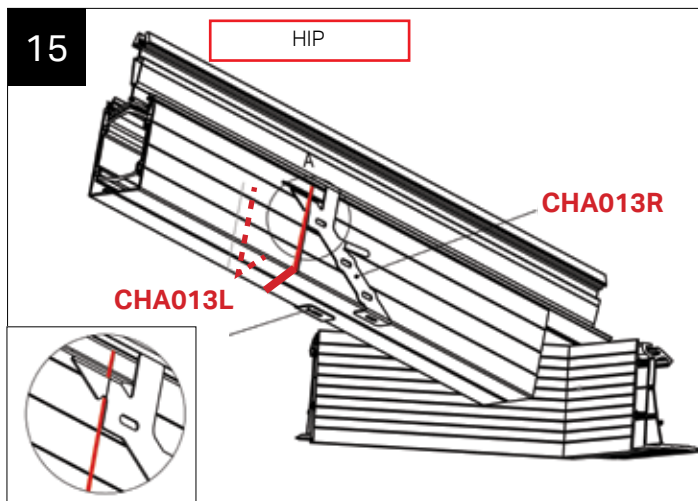

Take the bracket CHA013 L or R (right hand illustrated) and line up with datum line (see inset diagram)

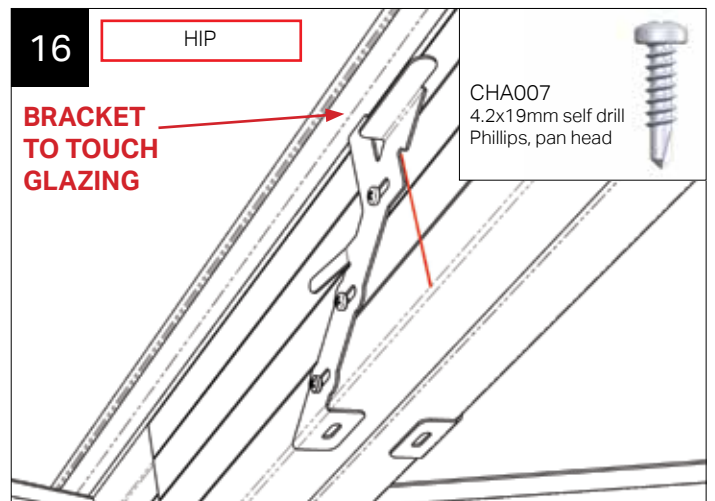

Now attach the bracket with a minimum of two CHA007 4.2 x 19 mm self drill panhead Phillips screws. Repeat the process for the opposite hand bracket.

INSTALLATION - BOLSTER BARS - SPLAYED

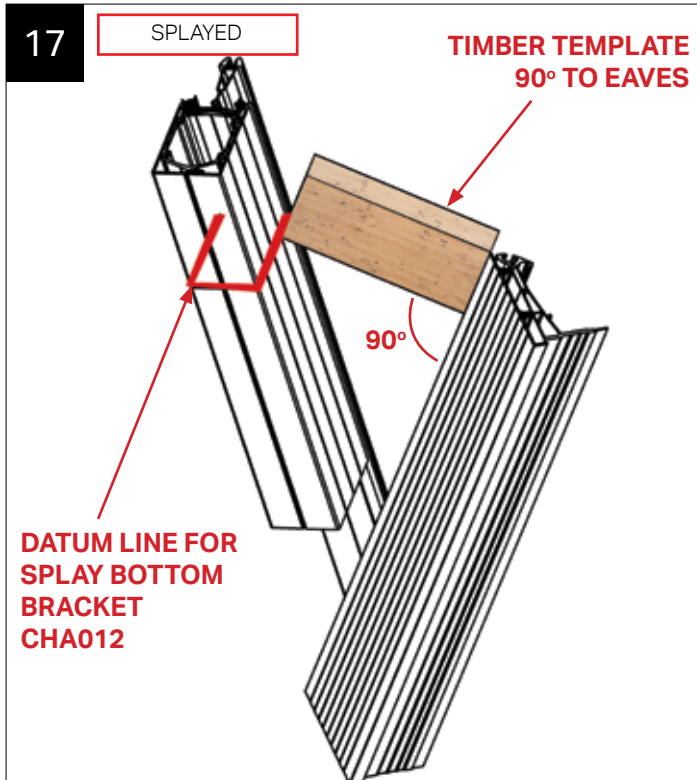

From the location plan, find the dimension for the splayed bar and cut a piece of timber to that length. Hold the timber along the top edge of the PFTB fascia board and then against the glazing. Mark a line all the way round the splayed bar cladding.

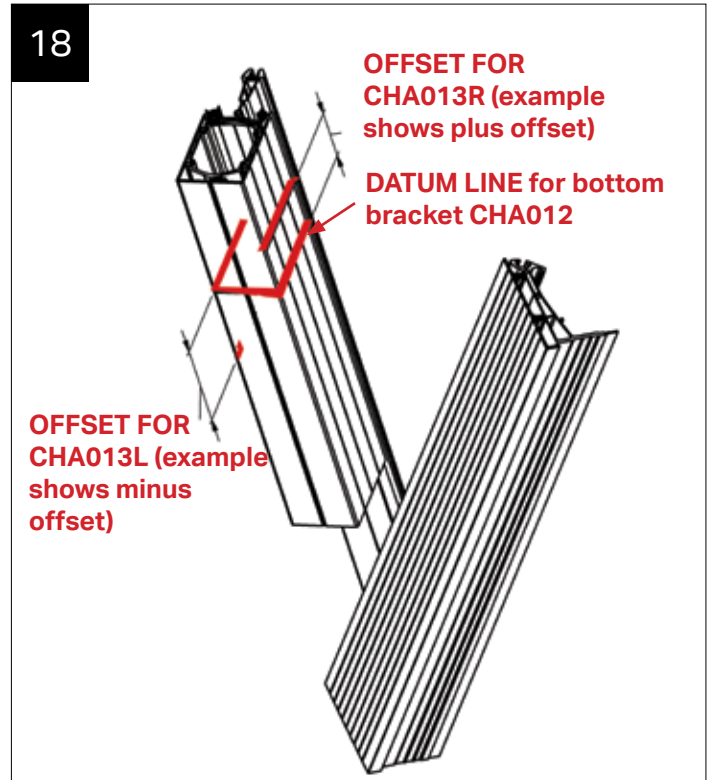

Using the location plan, measure and mark either the positive offset or the minus offset.

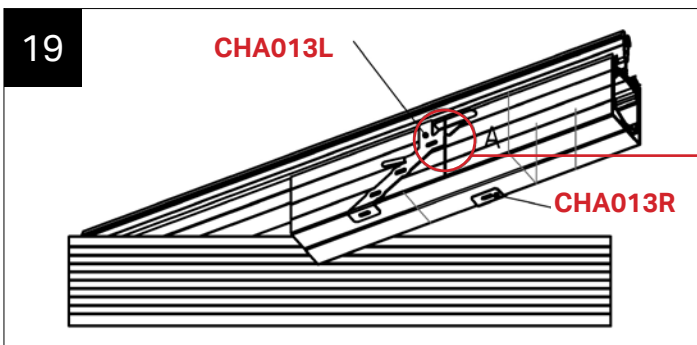

Take the bracket CHA013 L or R and line up with offset line. Now attach the bracket with a minimum of two CHA007 4.2 x 19mm self drill panhead Phillips screws. Repeat the process for the opposite hand bracket.

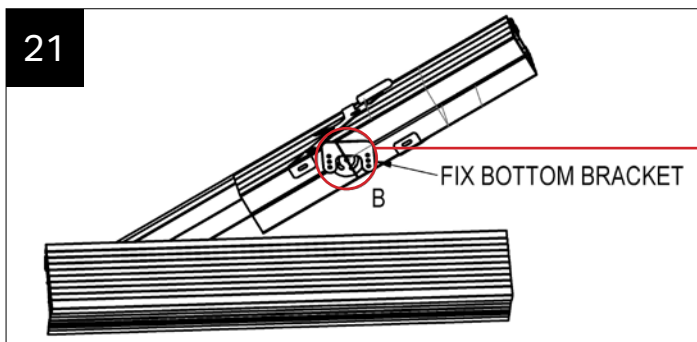
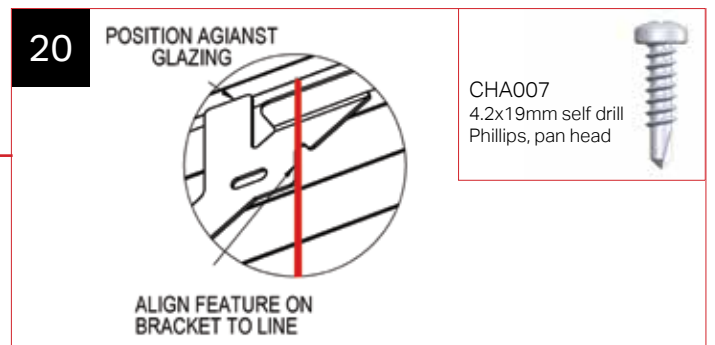

Then take the CHA012 splay bar bracket and line it up with the datum line – see illustration alongside. Fasten through centre hole with one CHA008 4.8 x 32mm self drill panhead Phillips screw.

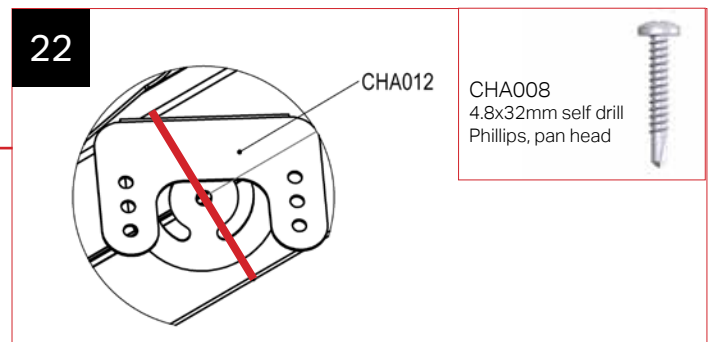

INSTALLATION - BOLSTER BARS

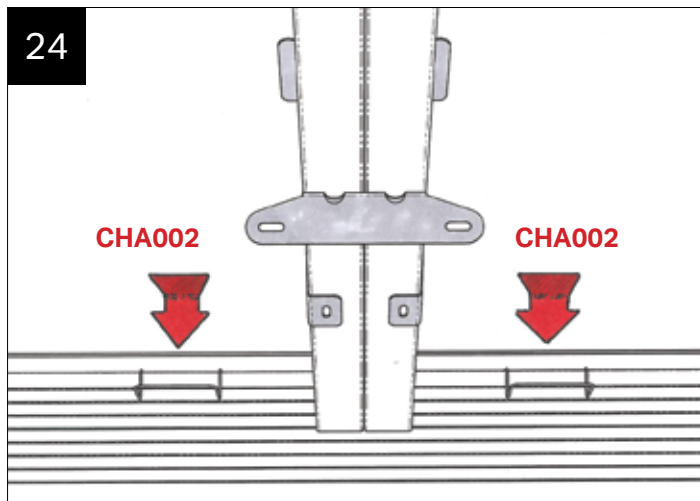
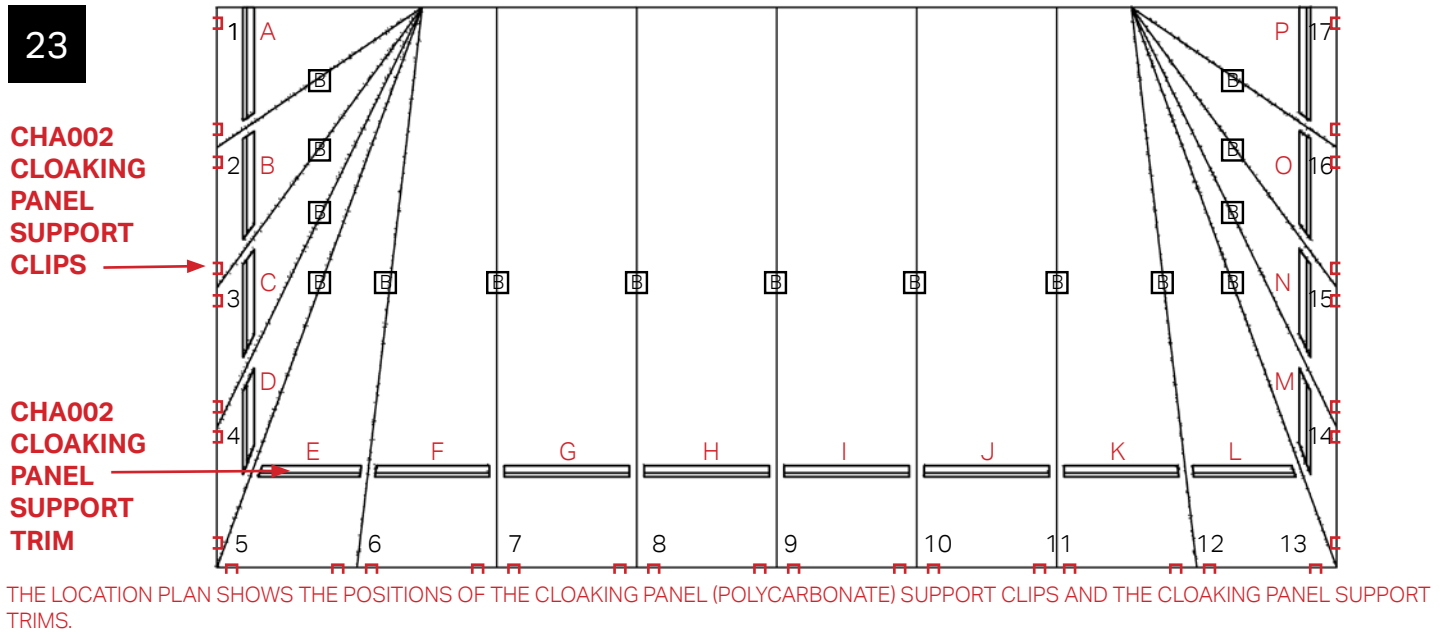

A cloaking panel (polycarbonate) support clip is placed each side of the transom bolster bars.

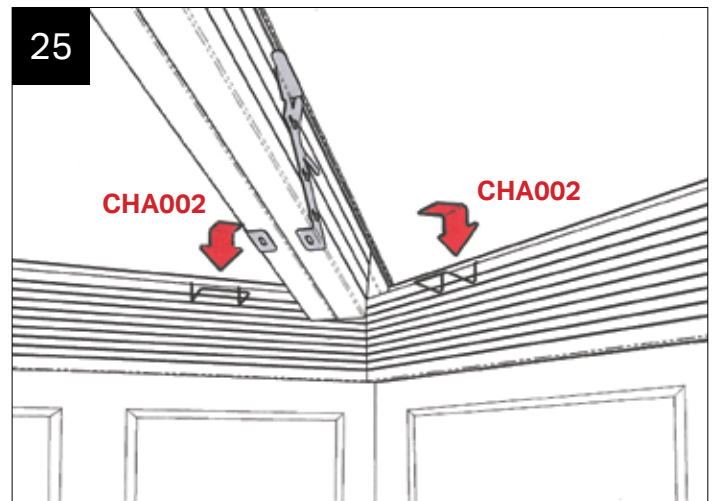

The support clips are located over the PFTB fascia board at hips and splayed bar positions too.

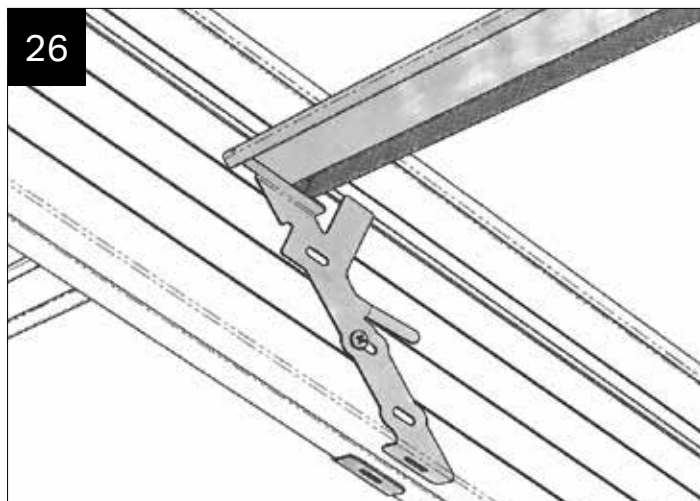

Offer into position the cloaking panel (polycarbonate) support trim – this is lifted up and over CHA013

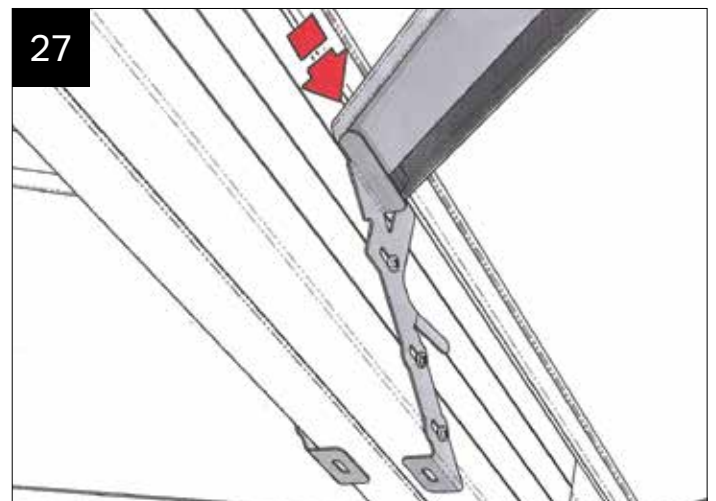

The cloaking panel support trim locks into position.

INSTALLATION - BOLSTER BARS

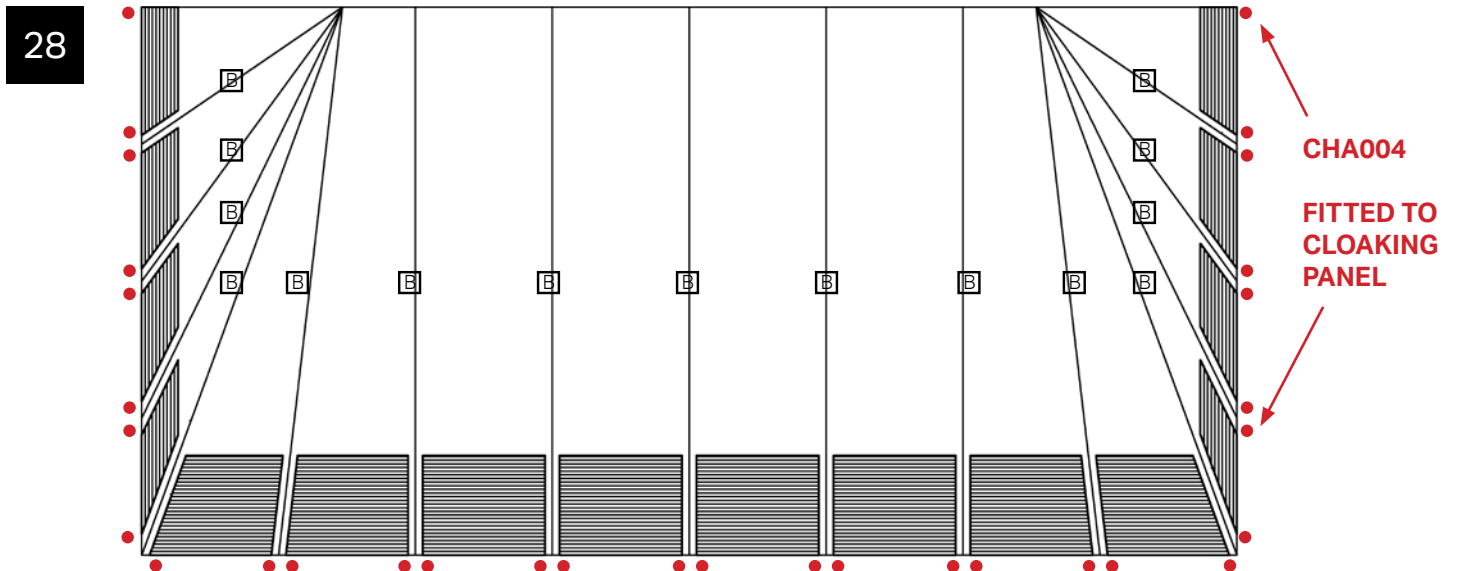

NOW IS THE TIME TO INSTALL THE POLYCARBONATE CLOAKING SCREEN PANELS – SEE LOCATION PLAN TO FIND THE PANELS YOU NEED.

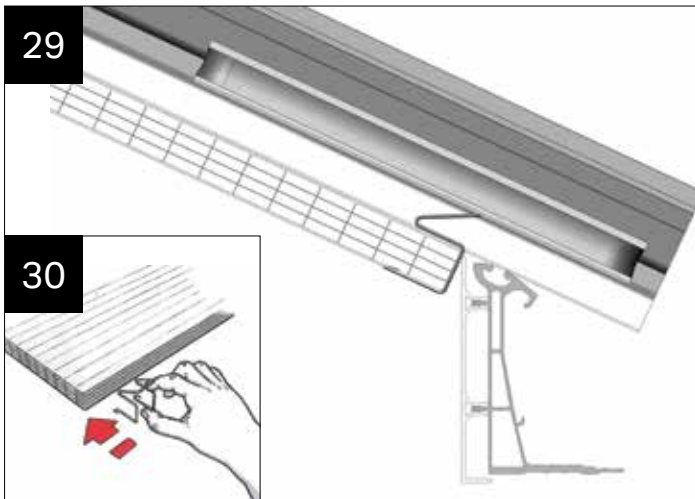

Now attach these polycarbonate support spacers CHA004 – attach to the leading edge of the polycarbonate (silver side up). Location plan and '●' symbol shows where they are fitted.

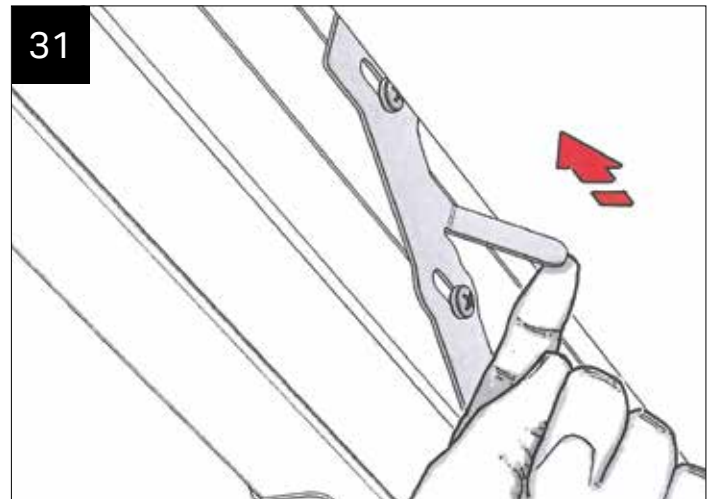

Fit the cloaking panel (silver side up) between the bolsters supported at the eaves by the support clips CHA002. Next bend back the long legged tabs on the CHA013 to hold the polycarbonate cloaking trim in its final position.

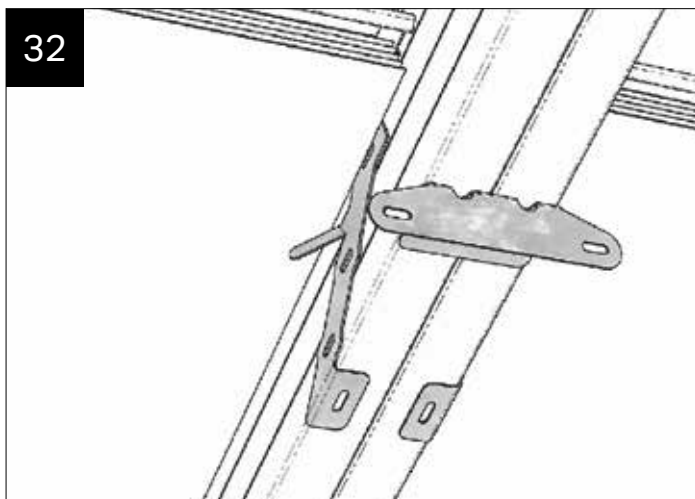

This is how the transom bolster bar should look at this stage.

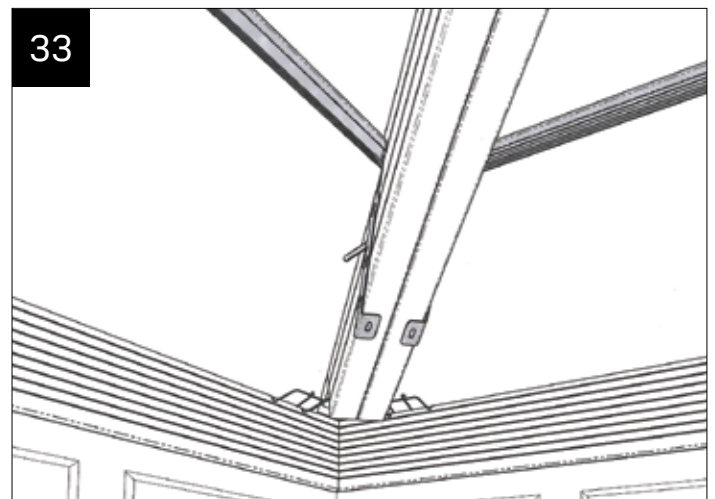

And this is how the Georgian bolster bar should look too.

INSTALLATION - BOLSTER BARS

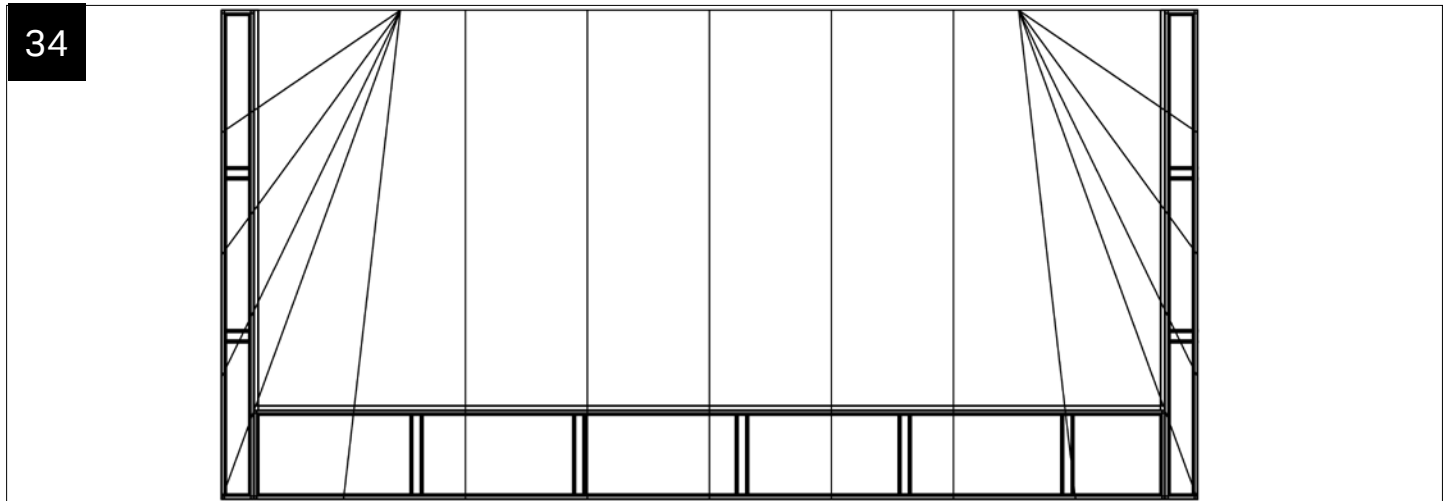

IMPORTANT NOTE. NOW CHECK ON THE LOCATION PLAN WHETHER THE HORIZONTAL FRAME IS FOR 'ON FASCIA' FIXING OR 'BELOW FASCIA' FIXING STEPS 46 AND 47.

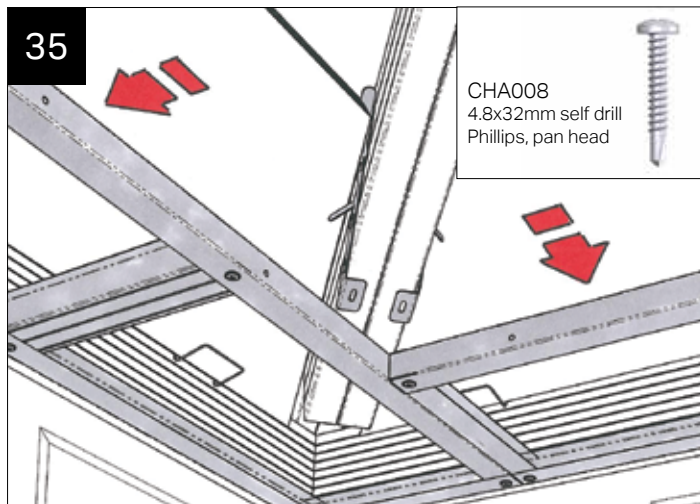

Having referred to the location plan, offer up the first horizontal ladder- a temporary timber support leg will help you here. Use 4.8 x 32mm at 250mm centres into pre punched holes to attach the ladder. Connect horizontal ladders together using two CHA006 fixings. Add adjacent horizontal ladders.

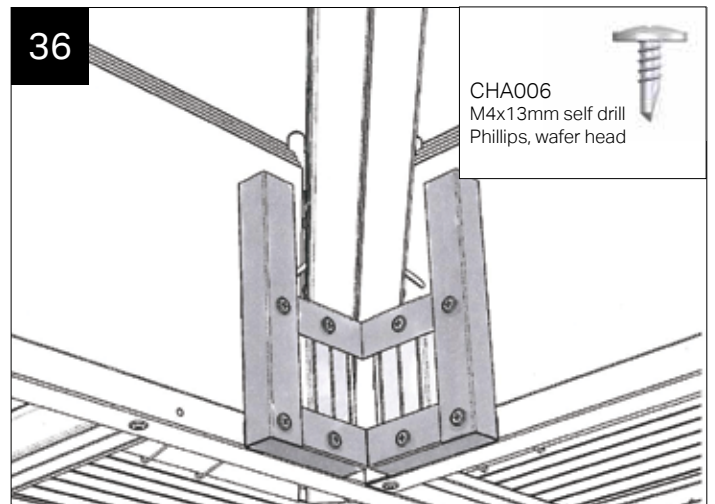

Unpack the bolster corner infill – it is supplied flat and needs to be unpacked and folded into a right angle. Taped to it are two 100mm fixing channels – place these on one side for later. Offer up the corner infill and screw through horizontal ladder into the back of the corner infill – use two CHA006 M4 x 13mm self drill wafer head Phillips screws per side of the corner.

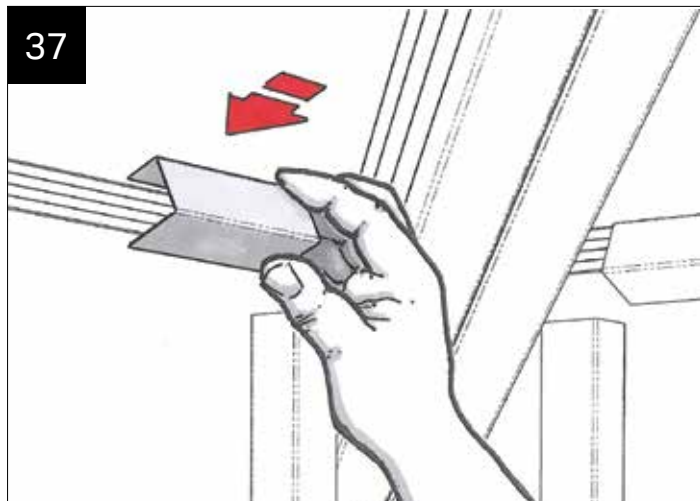

Now take the two 100mm pieces of fixing channels and slip over the two polycarbonate panels adjacent to the hip bar

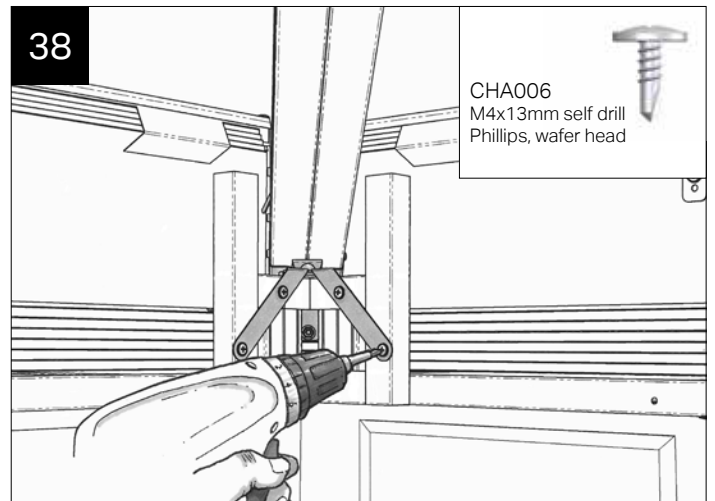

Next take the CHA010 hip bracket assembly and fasten the 'V' shaped element into the corner infill using 4 CHA006 M4 x 13mm self drill wafer head Phillips screws.

INSTALLATION - BOLSTER BARS

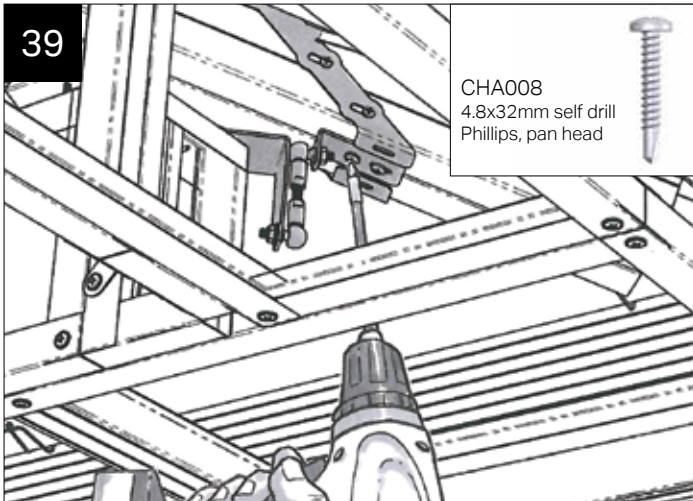

Now, screw up through the horizontal ladders to complete the assembly of the CHA010 hip bracket assembly using two CHA008 4.8 x 32mm self drill panhead Phillips screws. Ensure horizontal ladders are level.

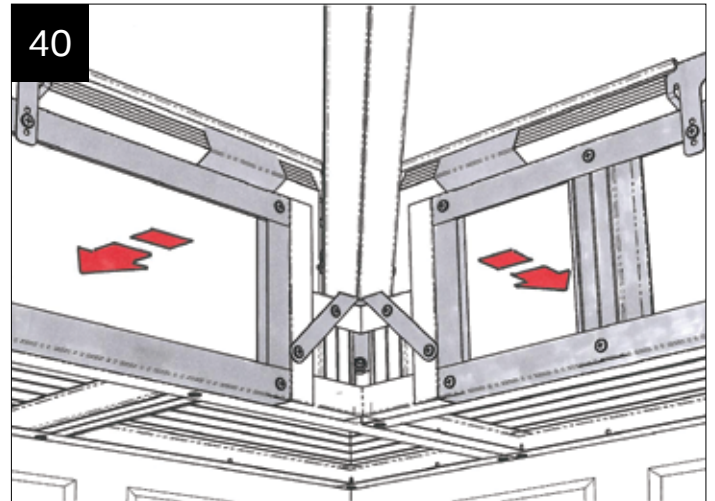

Using the location plan, choose the matching vertical ladder and offer it into position - hold firmly whilst attaching to the matching horizontal ladder using M4 x 13mm fixing, at 250mm centres into pre punched holes. Ensure the vertical ladder is behind the brackets.

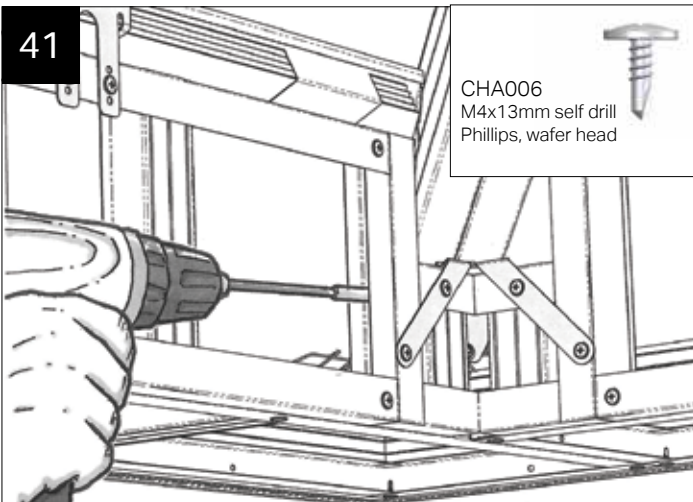

Butt the vertical ladder into the side of the corner infill - secure using two CHA006 M4 x 13mm self drill wafer head Phillips screws. Use two per vertical ladder.

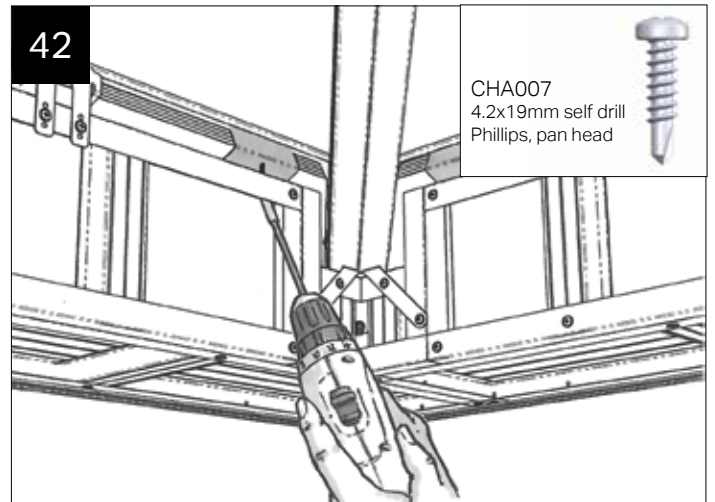

Now secure the top edge of the vertical ladder into the 100mm fixing channel - use two CHA007 4.2 x 19mm self drill panhead Phillips screws

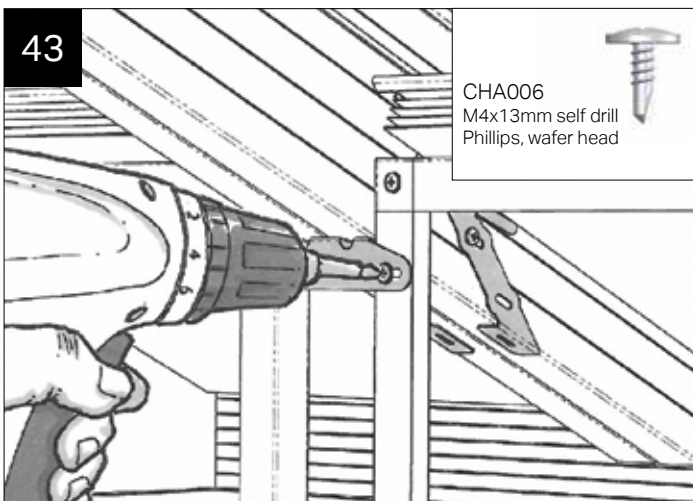

Secure the CHA009 bolster transom bracket at each side to the vertical ladder using CHA006 M4 x 13mm self drill panhead Phillips screw.

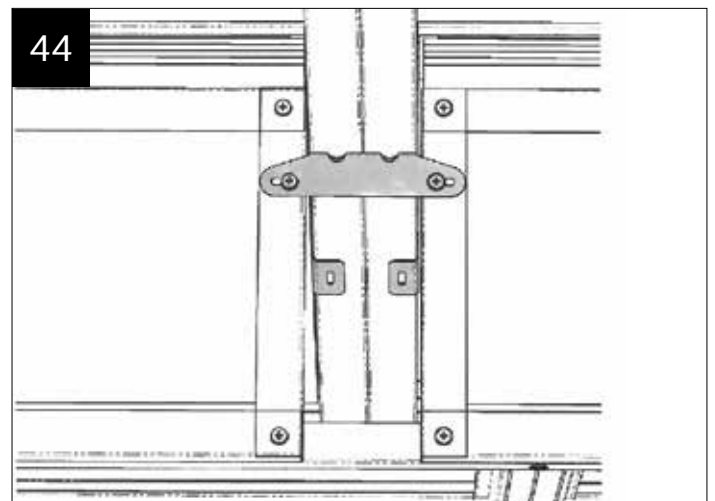

This is what the final transom bar should look like.

INSTALLATION - GABLE



GABLE BRACKET (left) CHA019L GABLE BRACKET (right) CHA019R



Using the location plan provided find the dimension for setting out the clip positions for the gable brackets. Measure up the bar from top edge of the fascia board and mark it.



Take the gable bracket (CHA019R right hand shown). The back edge of the bracket should butt up to the pencil line. Align the top face of the gable bracket with underside of starter bar cladding.

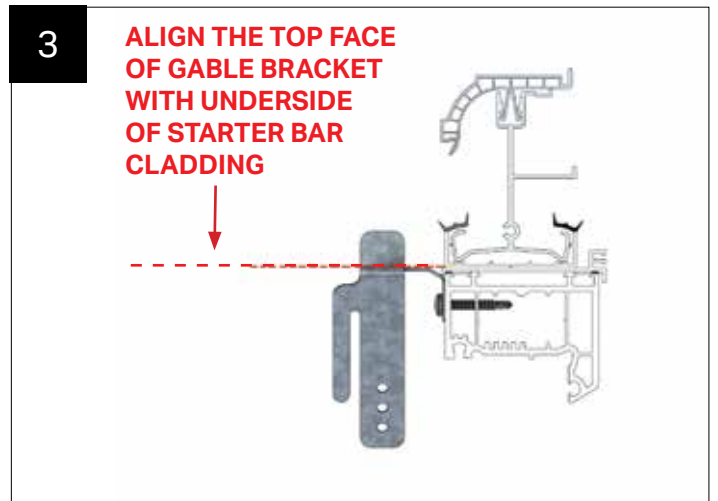

Attach gable bracket to frame using two of the CHA008 (4.8 x 32mm) self drill Phillips Pan Head screws supplied.



Offer into position the cloaking panel support trim - the nose of the closure trim must be notched back as shown (at the gable side only).



NOTE: AREA MARKED ABOVE TO BE NOTCHED BACK

INSTALLATION - GABLE

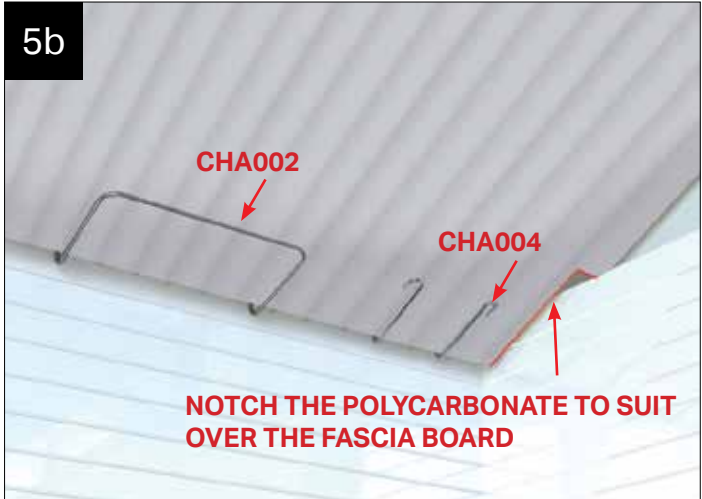

Referring to the location plan, take the appropriate piece of polycarbonate cloaking panel, mark and notch the corner as demonstrated.

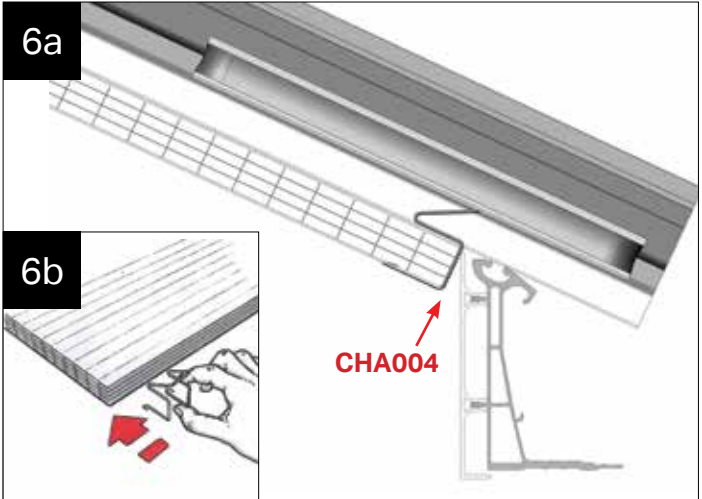

Attach CHA004 to the cloaking panel and fit as shown in the main Internal pelmet installation guide.









Fit the horizontal and vertical frames as shown in the main internal pelmet installation guide.



Fix the vertical frame into the fascia board using 2x CHA006 (M4 x 13mm) self drill Phillips, wafer head screws (supplied).

INSTALLATION - VALLEY

VALLEY BRACKET KIT CONTENT CHA014				No. Req
	Valley Fixing Plate		CHA016	x1
	WSR 4.8x70 Z Self Tapping Drill Point		CHA017	x2
	200x100x27x2.5 Thick Galvanised MS Strap		CHA018	x1
	Bag of 25 - M4 x 13 Self Drill Philips Wafer		CHA006	x1
	Poly Panel Spring Clip		CHA002	x4
	Poly Support Wire Form Bolster Spacer		CHA004	x2

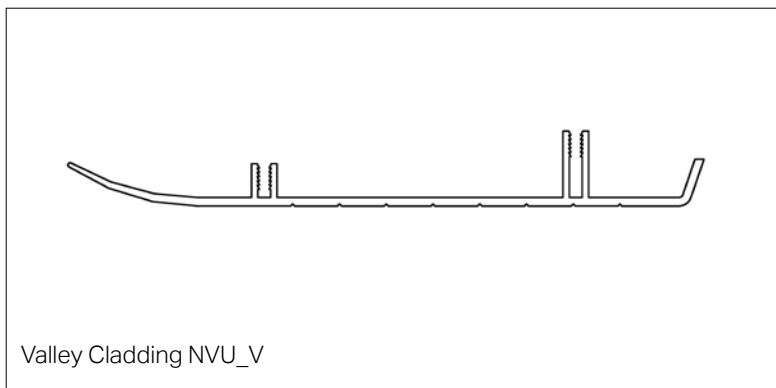

NOTE: The transom bracket CHA001 **MUST** be trimmed and adapted to suit situations where a transom bar, valley and pelmet vertical frame intercept, as shown above.

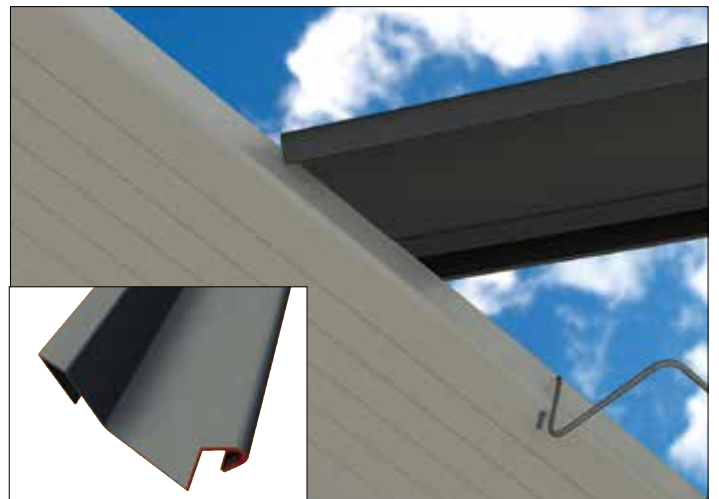

In valley situations the closure trim sits onto the valley drip profile. The nose of the closure trim must be notched as shown above, this allows the trim to sit flat.

INSTALLATION - VALLEY



VALLEY FIXING
PLATE CHA016

Mark out and cut the valley cladding and fix valley fixing plate by following steps 1 - 5.



Using a level, plumb up off the horizontal frame and mark the outer bottom edge of the valley cladding on both sides (Mark "A")

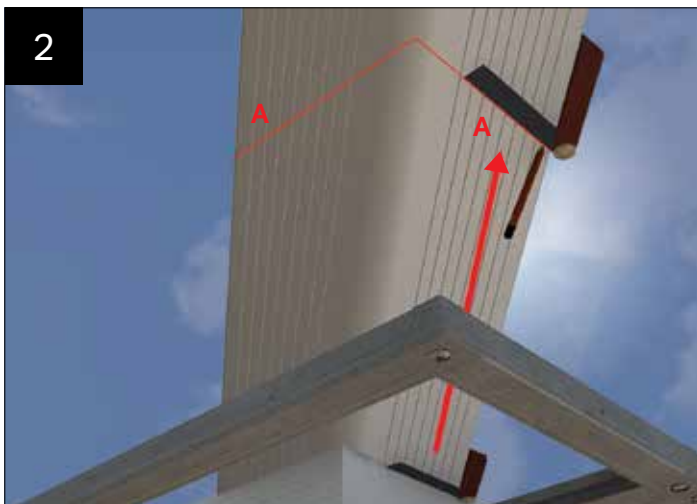

Using an angle finder (or joiners bevel). Draw a line on the valley cladding from the mark 'A' parallel to the eaves.

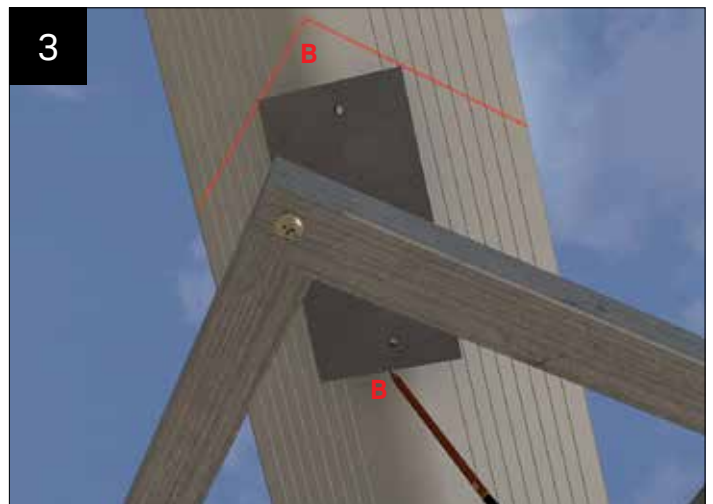

Temporarily position the valley fixing plate central of the valley with the top edges touching the marked lines. Mark either side of the plate (shown as 'B' on the cladding). Now remove valley fixing plate.

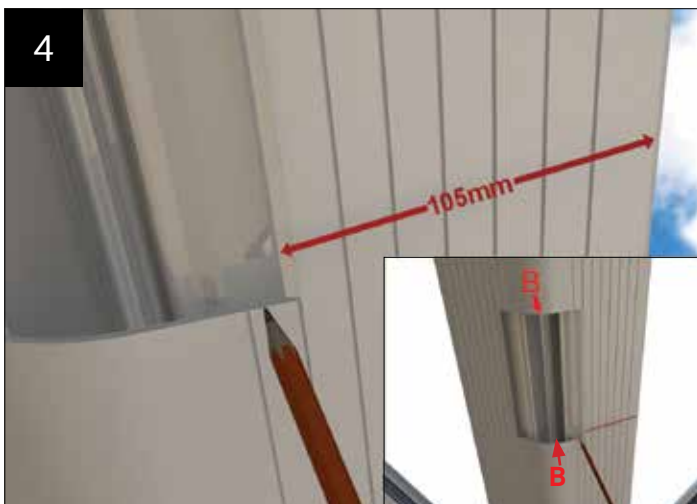

Then measure 105mm in from each side of the valley cladding and extend mark B top and bottom to form pencil rectangle. Cut out valley cladding.



Fit valley plate as shown to the valley wing central connector using CHA017 (2x4.8x70 self tapping screws).

NOTE: FOAM SIDE POSITION TOWARDS THE VALLEY.

INSTALLATION - VALLEY

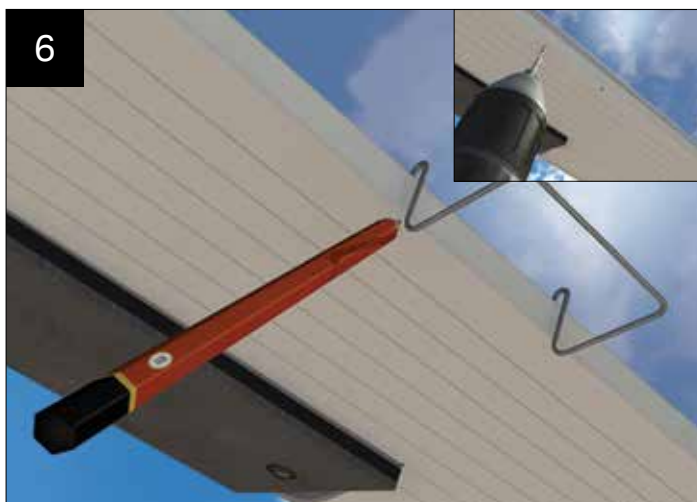

Fit the cloaking panel support clips CHA002 onto the valley cladding (2 per valley side supplied). Space out clips and temporarily hook over the valley cladding. Mark the leg positions then remove the clips. Drill a 5mm hole at each leg position as shown. **NOTE: AVOID DRILLING THROUGH THE VALLEY DRIP PROFILE**



Refit the clips with the clip leg extending through the holes.



Attach the cloaking panels and fit as shown in the main pelmet installation guide. (page 16).



Fit the valley corner infill panel to the horizontal frame, level up and secure to the valley plate.



FIT THE STRAP CHA018 USING M4x13 SELF DRILL SCREWS, to the valley corner infill panel and the valley fixing plate. It may be necessary to bend CHA008 to suit.



Fit the vertical frames. Fix the frames into the valley corner infill and the horizontal frames.

INSTALLATION - VALLEY

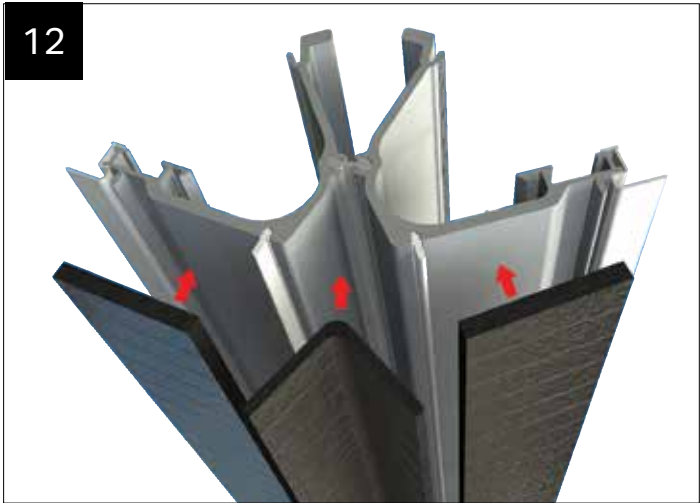

Fit the insulation strip BG1065/3 between and onto the valley wings. Remove liner from the foam strip and stick into position.



Using the bracket positions, level through and mark off the valley marked 'C'.



Measure and fit the standard valley undercladding NVU-V between the eaves and mark 'C'. Scribe to suit.



Fit the valley plate CHA016 (refer to steps 1-5, valley standard classic)



Valley infill panel fitted to horizontal frame, as image 10.



Classic Plus Valley cladding being fitted against pelmet. After plasterboard and skim.

INSTALLATION - INTEGRAL BOXGUTTER



1
If not already fitted, attach box gutter insulation foam to the upper section of box gutter.



2
Fit length of LHE---/2 to the upper section of box gutter



3
Using LHE---/2 as a datum, measure and mark the positions of the brackets in line with the dimensions given in the provided paperwork.



3a
FITTER TIP: If possible, check and line through with the bracket position on the adjacent full length bar. Mark the bracket positions on the bars off the box gutter.



4
Fit brackets in marked positions on the bars as per standard installation and fit closure trims CHA---GR/5 according to layout plan.



5
Fit the polycarbonate modesty panels and bend over bracket legs to secure.

INSTALLATION - INTEGRAL BOXGUTTER



Cross section shown for reference.



Fit back horizontal frame using CHA008 (bag of 25) as per standard installation.



Screw split horizontal frames together using CHA006 (bag of 25).



Fix the vertical frames in place using CHA006 (bag of 25) as per standard installation.



WENDLAND

R O O F S O L U T I O N S

www.Wendland.uk.com

© Wendland - Our policy is one of continuous improvement and we reserve the right to change specification and design at any time without prior notice

Job No. 3705 WENDLAND INSTALL V6 02/20
WIG001